

Rectifiers

6-pole bridge rectifier

Dimensions

BEG-162-270

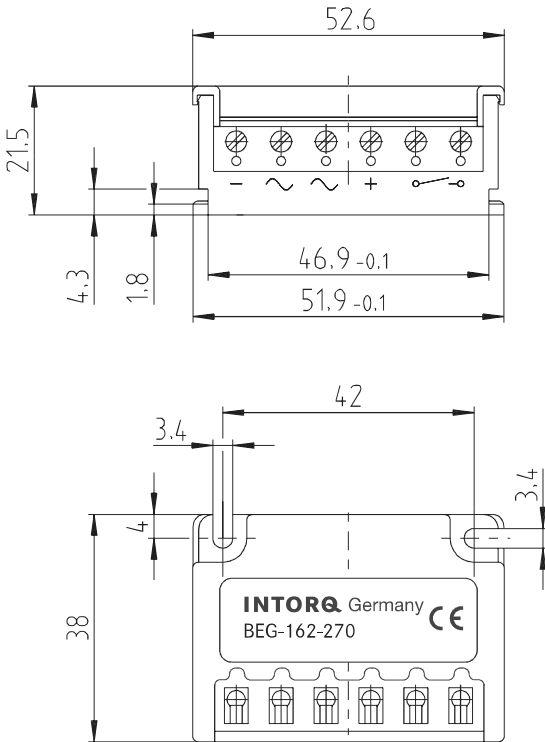

BEG-161-270

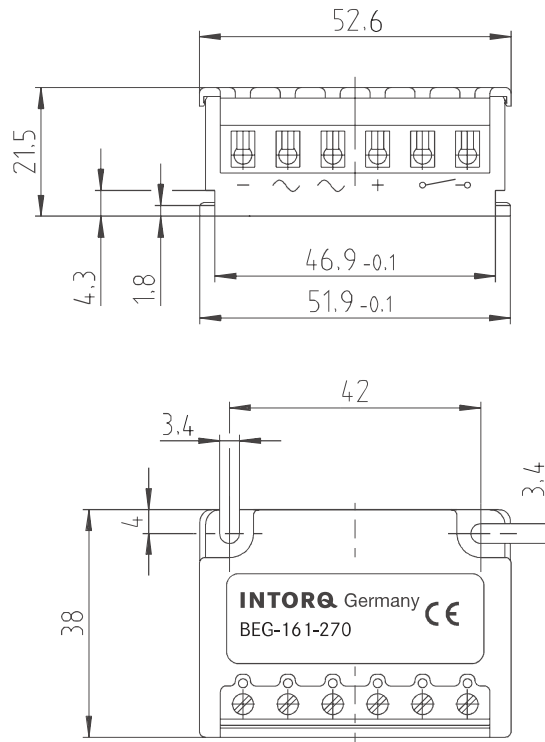

6-pole bridge rectifier

BEG-162-270

BEG-161-270

Application area

Current supply for spring-applied brakes from AC mains (normal excitation).

Example: 205 V coil on 230 V mains

Technical data

Max. mains voltage 270 V~

Max. DC current at 60°C 0.75 A

Max. ambient temperature 80°C

The rectifiers are protected against overvoltage by input and output varistors.

BEG-162-270/161-270/262-460/261-460 rectifiers also contain the spark suppressors required by VDE 0580 Section 26.

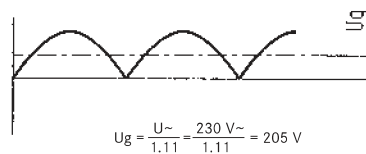

Rectifiers

Fastening options 6-pole rectifier

