

Communication Manual

8400

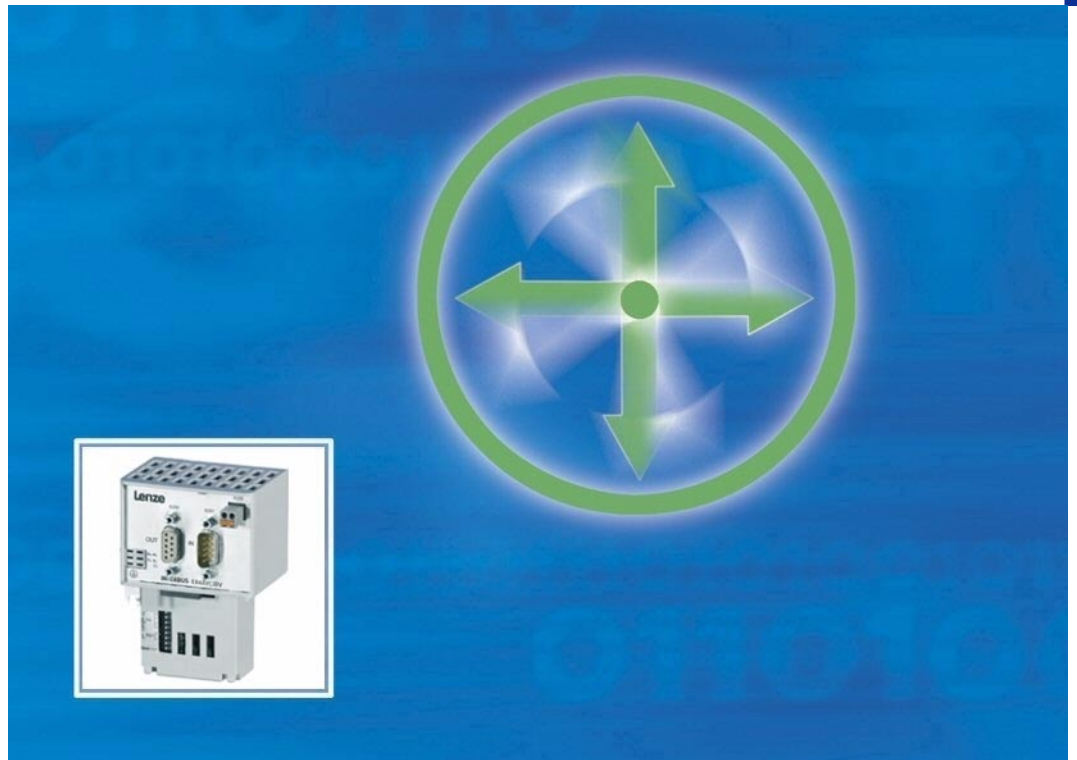

E84AYCIB

INTERBUS communication module

kabea GmbH (Innovative Antriebe)
Kößmannstraße 47, D-66538 Neunkirchen
Telefon:+49 (0)6821/919238, Fax:+49 (0)6821/919239
<https://www.becker-antriebstechnik.org/>

kabea GmbH (Innovative Antriebe)
Kossmannstraße 47, D-66538 Neunkirchen
Telefon:+49 (0)6821/919238, Fax:+49 (0)6821/919239
<https://www.becker-antriebstechnik.org/>

Contents

1	<u>About this documentation</u>	6
1.1	<u>Document history</u>	8
1.2	<u>Conventions used</u>	9
1.3	<u>Terminology used</u>	10
1.4	<u>Notes used</u>	11
2	<u>Safety instructions</u>	12
2.1	<u>General safety instructions and application notes</u>	12
2.2	<u>Device- and application-specific safety instructions</u>	13
2.3	<u>Residual hazards</u>	13
3	<u>Product description</u>	14
3.1	<u>Application as directed</u>	14
3.2	<u>Identification</u>	14
3.3	<u>Product features</u>	15
3.4	<u>Terminals and interfaces</u>	16
4	<u>Technical data</u>	17
4.1	<u>General data and operating conditions</u>	17
4.2	<u>Protective insulation</u>	18
4.3	<u>Protocol data</u>	21
4.4	<u>Communication time</u>	21
4.5	<u>Dimensions</u>	22
5	<u>Installation</u>	23
5.1	<u>Mechanical installation</u>	24
5.1.1	<u>Mounting for standard devices 0.25 kW and 0.37 kW</u>	24
5.1.2	<u>Mounting for standard devices from 0.55 kW onwards</u>	25
5.1.3	<u>Replacing the communication module</u>	26
5.2	<u>Electrical installation</u>	27
5.2.1	<u>EMC-compliant wiring</u>	27
5.2.2	<u>Network topology</u>	27
5.2.3	<u>INTERBUS connection</u>	28
5.2.4	<u>Specification of the bus cable</u>	30
5.2.5	<u>Bus cable length</u>	30
5.2.6	<u>External voltage supply</u>	31

kabea GmbH (Innovative Antriebe)
 Koßmannstraße 47, D-66538 Neunkirchen
 Telefon:+49 (0)6821/919238, Fax:+49 (0)6821/919239
<https://www.becker-antriebstechnik.org/>

6	<u>Commissioning</u>	33
6.1	<u>Before initial switch-on</u>	33
6.2	<u>Possible settings through DIP switch</u>	34
6.2.1	<u>Setting the number of process data words (PD)</u>	35
6.2.2	<u>Setting the number of parameter data words (PCP)</u>	36
6.2.3	<u>Setting the baud rate</u>	37
6.3	<u>Settings in the »Engineer«</u>	38
6.4	<u>Initial switch-on</u>	39
7	<u>Data transfer</u>	40
8	<u>Process data transfer</u>	41
8.1	<u>Access to process data / PDO mapping</u>	41
8.2	<u>Preconfigured port interconnection of the process data objects (PDO)</u>	42
8.3	<u>Freely configuring the port interconnection of the process data objects (PDO)</u>	43
9	<u>Parameter data transfer</u>	48
9.1	<u>Addressing of the parameter data</u>	48
9.2	<u>Initialising PCP communication</u>	48
9.3	<u>Supported PMS services</u>	49
9.3.1	<u>Initiate</u>	49
9.3.2	<u>Abort</u>	49
9.3.3	<u>Reject</u>	49
9.3.4	<u>Read / Write</u>	50
9.3.5	<u>Get-OD</u>	50
9.3.6	<u>Identify</u>	51
9.3.7	<u>Status</u>	52
10	<u>Monitoring</u>	53
11	<u>Diagnostics</u>	54
11.1	<u>LED status displays</u>	54
11.1.1	<u>Module status displays</u>	55
11.1.2	<u>Fieldbus status displays</u>	56
11.2	<u>Querying the current bus status</u>	57
11.3	<u>Diagnostic data</u>	58
12	<u>Error messages</u>	59
12.1	<u>Short overview (A-Z) of the INTERBUS error messages</u>	59
12.2	<u>Possible causes and remedies</u>	60

13	<u>Parameter reference</u>	63
13.1	<u>Parameters of the communication module</u>	63
13.2	<u>Table of attributes</u>	70
14	<u>Index</u>	72

kabea GmbH (Innovative Antriebe)
Kossmannstraße 47, D-66538 Neunkirchen
Telefon:+49 (0)6821/919238, Fax:+49 (0)6821/919239
<https://www.becker-antriebstechnik.org/>

1 About this documentation

Contents

The descriptions contained in this documentation refer only to the E84AYCIB communication module (INTERBUS).



Note!

This documentation supplements the **mounting instructions** supplied with the communication module and the **"Inverter Drives 8400" hardware manual**.

The features and functions of the communication module are described in detail.

Typical applications are illustrated by means of examples.

This documentation also contains:

- ▶ Safety instructions that must be observed
- ▶ Key technical data relating to the communication module
- ▶ Information about the versions of the Lenze standard devices to be used
- ▶ Notes on troubleshooting and fault elimination

The theoretical concepts are only explained to the level of detail required to understand the function of the communication module.

Depending on the software version of the controller used and the version of the »Engineer« software installed, the screenshots provided in this documentation may not match up with those displayed by your »Engineer«.

This documentation does not describe any software provided by other manufacturers. No liability can be accepted for corresponding data provided in this documentation. For information on how to use the software, please refer to the host system (master) documents.

All product names mentioned in this documentation are trademarks of their respective owners.



Tip!

Detailed information on the INTERBUS can be found on the internet page of the INTERBUS user organisation:

www.interbusclub.com

kabea GmbH (Innovative Antriebe)
Kößmannstraße 47, D-66538 Neunkirchen
Telefon:+49 (0)6821/919238, Fax:+49 (0)6821/919239
<https://www.becker-antriebstechnik.org/>

Target group

This documentation addresses to people involved in configuring, installing, commissioning and maintaining a machine's networking and remote maintenance features.



Tip!

You will find documentation and software updates relating to Lenze products on the Internet, in the "Services & Downloads" area at:

www.Lenze.com

Validity information

The information in this documentation applies to the following devices:

Extension module	Type designation	From hardware version	From software version
INTERBUS communication module	E84AYCIB	VA	01.00

kabea GmbH (Innovative Antriebe)
Kößmannstraße 47, D-66538 Neunkirchen
Telefon:+49 (0)6821/919238, Fax:+49 (0)6821/919239
<https://www.becker-antriebstechnik.org/>

1.1 Document history

Material number	Version			Description
13295951	1.0	06/2009	TD17	First edition
13320780	2.0	11/2009	TD17	Parameter descriptions updated.
13329723	3.0	02/2010	TD17	Chapters "Diagnostics" and "Installation" updated.
13362260	4.0	11/2010	TD17	General revision

Your opinion is important to us!

These instructions were created to the best of our knowledge and belief to give you the best possible support for handling our product.

Perhaps we have not succeeded in achieving this objective in every respect. If you notice this, please send your suggestions and points of criticism in a short e-mail to:

feedback-docu@Lenze.de



Thank you very much for your support.

Your Lenze documentation team

kabea GmbH (Innovative Antriebe)
Kossmannstraße 47, D-66538 Neunkirchen
Telefon:+49 (0)6821/919238, Fax:+49 (0)6821/919239
<https://www.becker-antriebstechnik.org/>

1.2 Conventions used

This documentation uses the following conventions to distinguish between different types of information:

Type of information	Identification	Examples/notes
Spelling of numbers		
Decimal	Standard notation	Example:1234
Hexadecimal	0x[0 ... 9, A ... F]	Example: 0x60F4
Binary • Nibble	In quotation marks Point	Example: '100' Example: '0110.0100'
Decimal separator	Point	The decimal point is always used. For example: 1234.56
Text		
Program name	» «	PC software Example: Lenze »Engineer«
Control element	Bold	The OK button ... / The Copy command ... / The Properties tab ... / The Name input field ...
Hyperlink	<u>Underlined</u>	Optically highlighted reference to another subject which is activated with a mouse-click.
Symbols		
Page reference	 9	Optically highlighted reference to another page which is activated with a mouse-click.
Step-by-step instructions		Step-by-step instructions are indicated by a pictograph.

1.3 Terminology used

Term	Meaning
Standard device Controller	Lenze frequency inverter from the "Inverter Drives 8400" product series, with which the communication module can be used. ▶ Application as directed (□ 14)
»Engineer«	Lenze software, supporting you during the entire life cycle of a machine - from the planning phase to maintenance.
Code	"Container" for one or more parameters which you can use to parameterise or monitor the communication module.
Subcode	If a code contains several parameters, the individual parameters are stored under "subcodes". This manual uses a slash "/" as a separator between the code and subcode (e.g. "C00118/3").
PCP	Peripherals Communication Protocol (parameter data transmission)
PD	Process data / process data words
PDO	Process data object
PDU	Process Data Unit
PMS	Peripheral Message Specification
HW	Hardware
SW	Software

kabea GmbH (Innovative Antriebe)
Kößmannstraße 47, D-66538 Neunkirchen
Telefon:+49 (0)6821/919238, Fax:+49 (0)6821/919239
<https://www.becker-antriebstechnik.org/>

1.4 Notes used

The following signal words and symbols are used in this documentation to indicate dangers and important information:

Safety instructions

Layout of the safety instructions:



Pictograph and signal word!

(characterise the type and severity of danger)

Note

(describes the danger and gives information about how to prevent dangerous situations)

Pictograph	Signal word	Meaning
	Danger!	Danger of personal injury through dangerous electrical voltage Reference to an imminent danger that may result in death or serious personal injury if the corresponding measures are not taken.
	Danger!	Danger of personal injury through a general source of danger Reference to an imminent danger that may result in death or serious personal injury if the corresponding measures are not taken.
	Stop!	Danger of property damage Reference to a possible danger that may result in property damage if the corresponding measures are not taken.

Application notes

Pictograph	Signal word	Meaning
	Note!	Important note to ensure trouble-free operation
	Tip!	Useful tip for simple handling
		Reference to another documentation

kabea GmbH (Innovative Antriebe)
 Koßmannstraße 47, D-66538 Neunkirchen
 Telefon:+49 (0)6821/919238, Fax:+49 (0)6821/919239
<https://www.becker-antriebstechnik.org/>

2 Safety instructions



Note!

It is absolutely vital that the stated safety measures are implemented in order to prevent serious injury to persons and damage to material assets.

Always keep this documentation to hand in the vicinity of the product during operation.

2.1 General safety instructions and application notes

- ▶ Lenze drive components ...
 - may only be used as directed.
 - ▶ [Application as directed](#) (14)
 - must never be commissioned if they display any signs of damage.
 - must never be modified technically.
 - must never be commissioned if they are not fully mounted.
 - must never be operated without the required covers.
 - can have live, moving and rotating parts during operation, depending on their degree of protection. Surfaces can be hot.
- ▶ The following applies to Lenze drive components ...
 - Only use accessories that have been approved for the product.
 - Only use genuine spare parts supplied by the manufacturer of the product.
- ▶ Observe all regulations for the prevention of accidents, directives and laws that apply to the location of use.
- ▶ Observe all the specifications contained in the enclosed documentation.
 - This is a precondition for ensuring safe, trouble-free operation and for making use of the stated product features.
 - ▶ [Product features](#) (15)
 - The specifications, processes, and circuitry described in this documentation are for guidance only and must be adapted to your own specific application. Lenze does not take responsibility for the suitability of the process and circuit proposals.
- ▶ All works on and with Lenze drive components may only be carried out by qualified personnel. According to IEC 364 and CENELEC HD 384 these are persons who ...
 - are familiar with installing, mounting, commissioning and operating the product.
 - have the qualifications necessary for their occupation.
 - know and are able to apply all regulations for the prevention of accidents, directives and laws that apply to the location of use.

kabea GmbH (Innovative Antriebe)
Kößmannstraße 47, D-66538 Neunkirchen
Telefon:+49 (0)6821/919238, Fax:+49 (0)6821/919239
<https://www.becker-antriebstechnik.org/>

2.2 Device- and application-specific safety instructions

- ▶ During operation, the communication module must be securely connected to the standard device.
- ▶ Use a safely separated power supply unit in accordance with EN 61800-5-1 ("SELV"/"PELV").
- ▶ Only use cables that meet the listed specifications.
 - ▶ [Specification of the bus cable](#) (☞ 30)



Documentation for the standard device, control system, plant/machine

All the other measures prescribed in this documentation must also be implemented. Observe the safety instructions and application notes contained in this manual.

2.3 Residual hazards

Protection of persons

- ▶ If Inverter Drives 8400 are used on a phase earthed mains with a rated mains voltage ≥ 400 V, external measures need to be implemented in order to provide reliable protection against accidental contact.
 - ▶ [Protective insulation](#) (☞ 18)

Device protection

- ▶ The communication module contains electronic components that can be damaged or destroyed by electrostatic discharge.
 - ▶ [Installation](#) (☞ 23)

kabea GmbH (Innovative Antriebe)
Kößmannstraße 47, D-66538 Neunkirchen
Telefon:+49 (0)6821/919238, Fax:+49 (0)6821/919239
<https://www.becker-antriebstechnik.org/>

3 Product description

3.1 Application as directed

The communication module ...

- ▶ Is an accessory module that can be used in conjunction with the following standard devices:

Product series	Type designation	From software version
Inverter Drives 8400 Stateline	E84AVSCxxxxx	04.00
Inverter Drives 8400 HighLine	E84AVHCxxxxx	04.00
Inverter Drives 8400 TopLine	E84AVTCxxxxx	01.00

- ▶ Is an item of equipment intended for use in industrial power systems
- ▶ Should only be used under the operating conditions prescribed in this documentation
- ▶ Should only be used in INTERBUS networks

Any other use shall be deemed inappropriate!

3.2 Identification

The type designation, hardware version, and software version of a communication module are indicated on its nameplate:

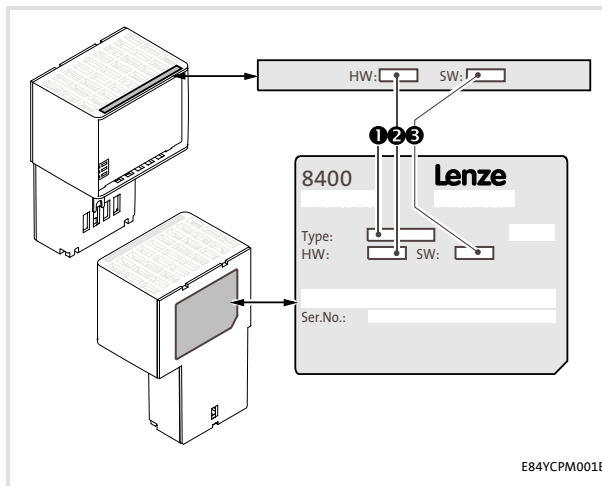

1 Type designation (type)

- E84 Product series
- A Version
- Y Module identification: extension module
- C Module type: communication module
- IB INTERBUS
- V/S V: Coated version
S: Standard version

2 Hardware version (HW)

3 Software version (SW)

[3-1] Identification data

3.3 Product features

- ▶ Interface module for the INTERBUS communication system for attachment to the expansion slots of Inverter Drives 8400
- ▶ The communication module can either be supplied internally by the 8400 standard device or externally by a separate voltage source.
- ▶ Slave functionality
- ▶ Access to all Lenze parameters
- ▶ DIP switch settings:
 - Number of process data words and parameter data words
 - Baud rate (500 kbps or 2 Mbps)
- ▶ Bus coupling via remote bus in accordance with the RS485 standard
- ▶ Up to 10 process data words are possible
- ▶ Support of the PMS services:
 - Initiate
 - Abort
 - Reject
 - Read
 - Write
 - Get-OD
 - Identify
 - Status

kabea GmbH (Innovative Antriebe)
Kößmannstraße 47, D-66538 Neunkirchen
Telefon:+49 (0)6821/919238, Fax:+49 (0)6821/919239
<https://www.becker-antriebstechnik.org/>

3.4 Terminals and interfaces

- ▶ 2 connections for the INTERBUS
 - 1 input (9-pole Sub-D plug)
 - 1 output (9-pole Sub-D socket)
- ▶ 2-pole plug connector with spring connection for the external voltage supply of the communication module
- ▶ DIP switch for setting the ...
 - Number of process data words and parameter data words
 - Baud rate
- ▶ Front LEDs for diagnostics ...
 - of the communication module voltage supply;
 - of the module status;
 - of the INTERBUS status.

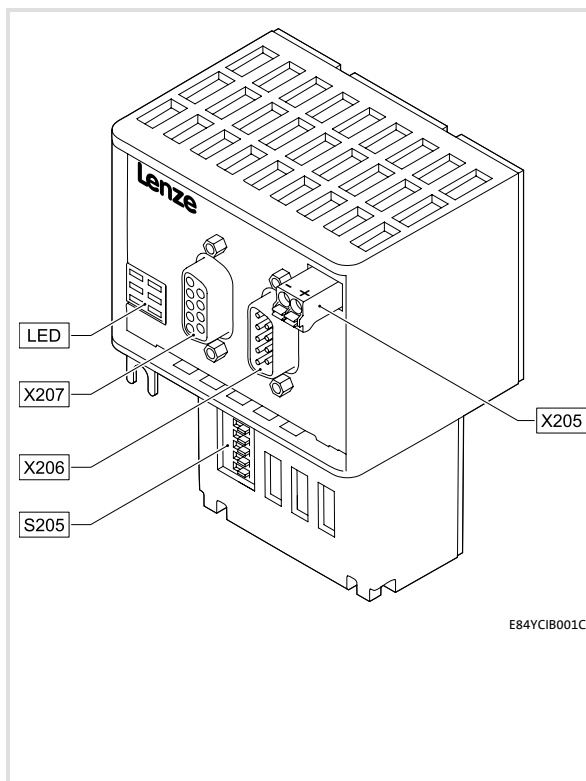

S205 DIP switch for setting the ...

- Number of process data words and parameter data words
- Baud rate

[▶ Possible settings through DIP switch \(□ 34\)](#)

X205 External voltage supply of the communication module

- 2-pole plug connector with spring connection

[▶ External voltage supply \(□ 31\)](#)

X206 INTERBUS input (IN)

- 9-pole Sub-D plug

X207 INTERBUS output (OUT)

- 9-pole Sub-D socket

[▶ Network topology \(□ 27\)](#)
[▶ INTERBUS connection \(□ 28\)](#)

MS 5 LED status displays for diagnostics

ME [▶ Module status displays \(□ 55\)](#)

BS [▶ Fieldbus status displays \(□ 56\)](#)

BE

DE

[3-2] E84AYCIB communication module (INTERBUS)

4 Technical data



"Inverter Drives 8400" hardware manual

This manual contains data on the **ambient conditions** and the **electromagnetic compatibility (EMC)** that also apply to the communication module.

4.1 General data and operating conditions

Field	Values
Order designation	<ul style="list-style-type: none"> E84AYCIBV (coated version) E84AYCIBS: (standard version)
Communication profile	INTERBUS
Interfaces	<ul style="list-style-type: none"> Input (IN): 9-pole Sub-D plug Output (OUT): 9-pole Sub-D socket
Communication medium	RS485
Network topology	Ring
Type of node	INTERBUS slave
Number of nodes	<ul style="list-style-type: none"> 1 master 512 slaves
Baud rate	500 kbps or 2 Mbps (can be set via DIP switch or code)
Max. cable length	<ul style="list-style-type: none"> 400 m at 500 kbps 150 m at 2 Mbps (between the individual INTERBUS nodes)
Process data words (PD) to be used	0 ... 10: 16 bits/word (can be set via DIP switch or code)
Parameter data words (PCP)	0, 1, 2, 4: 16 bits/word (can be set via DIP switch or code)
Max. number of data words	10 (PD + PCP): 16 bits/word
Max. PDU length	64 bytes
INTERBUS identification (module ID)	<ul style="list-style-type: none"> 3 = 0x3 (PCP 0 words) 227 = 0xE3 (PCP 1 word) 224 = 0xE0 (PCP 2 words) 225 = 0xE1 (PCP 4 words)
Voltage supply	External supply via the 2-pole plug connector <ul style="list-style-type: none"> "+": U = 24 V DC (21.6 V - 0 % ... 26.4 V + 0 %), I_{max} = 180 mA "-": Reference potential for external voltage supply
Conformities, approvals	CE

kabea GmbH (Innovative Antriebe)
 Koßmannstraße 47, D-66538 Neunkirchen
 Telefon:+49 (0)6821/919238, Fax:+49 (0)6821/919239
<https://www.becker-antriebstechnik.org/>

4.2 Protective insulation



Danger!

Dangerous electrical voltage

If Inverter Drives 8400 are used on a phase earthed mains with a rated mains voltage ≥ 400 V, external measures need to be implemented in order to provide reliable protection against accidental contact.

Possible consequences:

- Death or serious injury

Protective measures:

- If protection against accidental contact needs to be provided for the control terminals of the controller and for the connections of the plugged-in device modules, ...
 - a double isolating distance must exist.
 - the components to be connected must be provided with the second isolating distance.



Note!

The protective insulation provided in Inverter Drives 8400 is realised in accordance with EN 61800-5-1.

The illustration below ...

- ▶ shows the arrangement of the terminal strips and the separate potential areas of the controller.
- ▶ serves to determine the decisive protective insulation between two terminals located in differently insulated separate potential areas.



Note!

The INTERBUS input (X206) is isolated from the voltage supply (X205) and the INTERBUS output (X207).

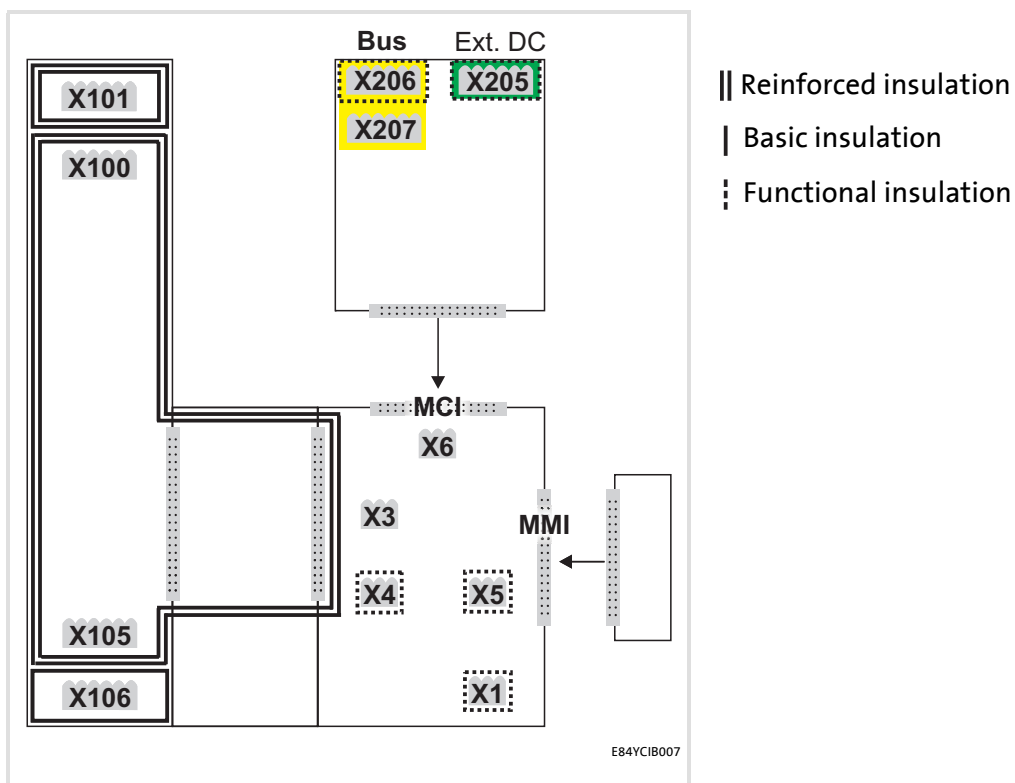

[4-1] Protective insulation in accordance with EN61800-5-1

kabea GmbH (Innovative Antriebe)
Kößmannstraße 47, D-66538 Neunkirchen
Telefon:+49 (0)6821/919238, Fax:+49 (0)6821/919239
<https://www.becker-antriebstechnik.org/>

Terminal strip	Connection
X100	Mains/DC-bus connection
X101	Relay contact
X105	Motor/brake resistor
X106	Motor PTC
X1	System bus (CANopen)
X3	Analog inputs/outputs
X4	Digital outputs
X5	Digital inputs
X6	Diagnostics
MCI	Slot for communication module
MMI	Slot for memory module

Example

Which type of protective insulation is used between the bus terminal of the device module in slot MCI and the mains terminal X100?

- ▶ The separate potential area with the better protective insulation is decisive.
 - The separate potential area of the device module bus terminal is "functionally insulated".
 - The separate potential area of the mains terminal has a "reinforced insulation".
- ▶ Result: The insulation between the mains terminal X100 and the bus terminal is of the "reinforced insulation" type.

4.3 Protocol data

Field	Values
Process data words	0 ... 10 words (16 bits/word)
Supported PMS services	<ul style="list-style-type: none"> • Initiate • Abort • Reject • Read • Write • Get-OD • Identify • Status

4.4 Communication time

The communication time is the time between the start of a request and the arrival of the corresponding response.

The communication times in the INTERBUS network depend on the...

- ▶ Processing time in the controller;
- ▶ Telegram runtime (baud rate / telegram length).

Processing time in the controller

The parameter data and process data are independent of each other.

Data	Processing time
Process data	Approx. 2 ms + 1 ms tolerance + runtime of the technology application used
Parameter data	Approx. 30 ms + 20 ms tolerance (typical) <ul style="list-style-type: none"> • Some codes may require a longer processing time (see software manual/ »Engineer« online help for Inverter Drives 8400).

kabea GmbH (Innovative Antriebe)
 Koßmannstraße 47, D-66538 Neunkirchen
 Telefon:+49 (0)6821/919238, Fax:+49 (0)6821/919239
<https://www.becker-antriebstechnik.org/>

4.5 Dimensions

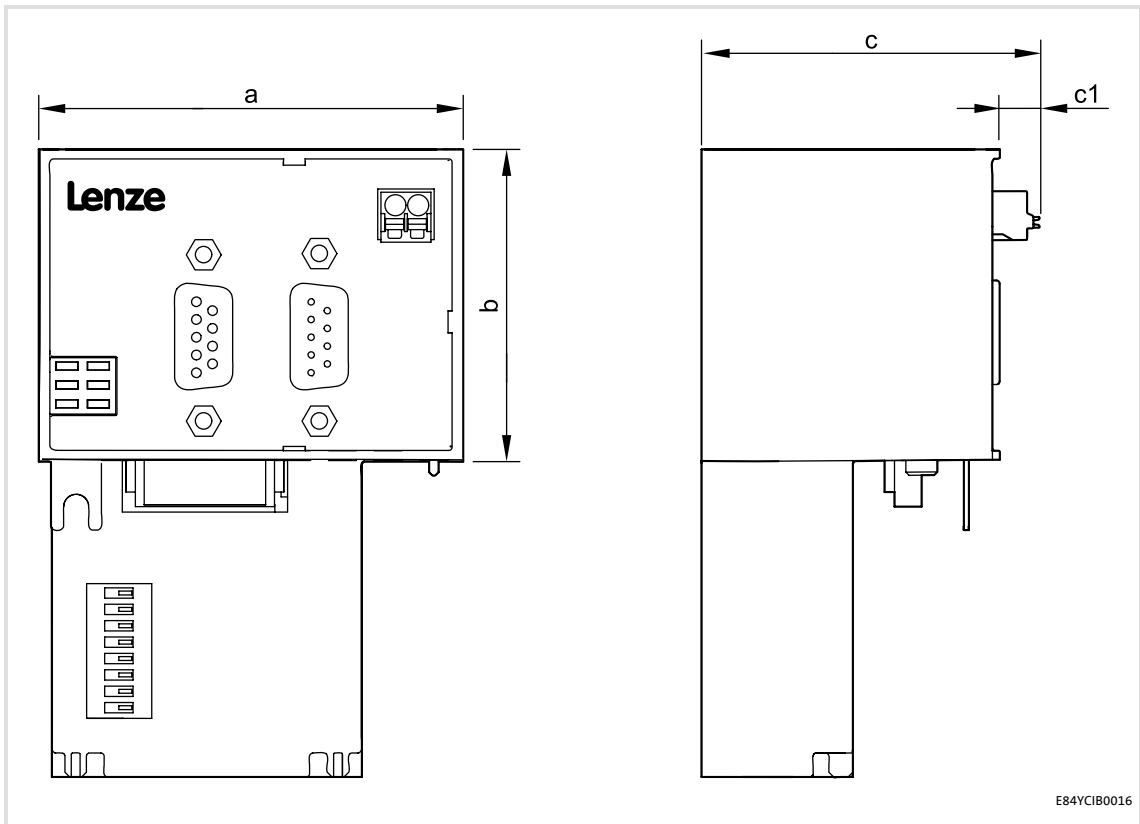

[4-2] Dimensions

Type	Dimensions [mm]			
	a	b	c	c1
E84AYCIB	67	50	57	8

kabea GmbH (Innovative Antriebe)
 Koßmannstraße 47, D-66538 Neunkirchen
 Telefon:+49 (0)6821/919238, Fax:+49 (0)6821/919239
<https://www.becker-antriebstechnik.org/>

5 Installation



Stop!

Electrostatic discharge

Electronic components within the communication module can be damaged or destroyed by electrostatic discharge.

Possible consequences:

- The communication module is damaged.
- Fieldbus communication is not possible or is faulty.

Protective measures:

- Ensure that you are free of electrostatic charge before you touch the module.

kabea GmbH (Innovative Antriebe)
Kößmannstraße 47, D-66538 Neunkirchen
Telefon:+49 (0)6821/919238, Fax:+49 (0)6821/919239
<https://www.becker-antriebstechnik.org/>

5.1 Mechanical installation

The communication module can be plugged into the MCI slot or removed from there while the controller is switched on. When the module is plugged in, it is recognised automatically and checked for plausibility regarding its function and version.

5.1.1 Mounting for standard devices 0.25 kW and 0.37 kW

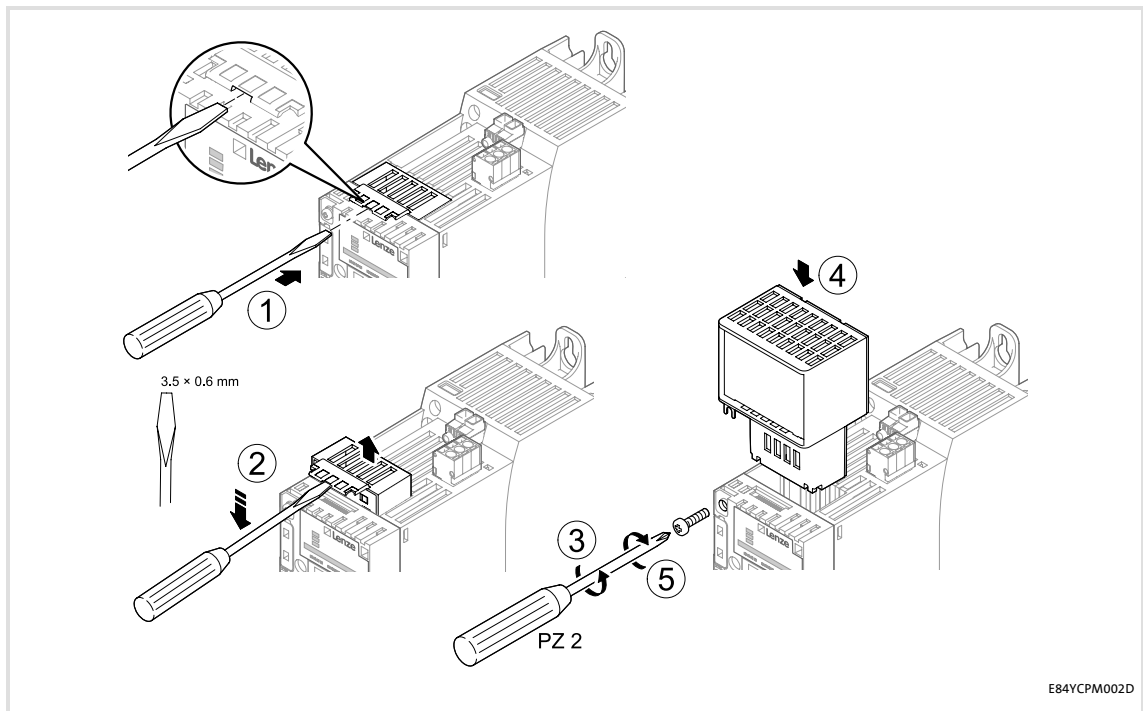

[5-1] Mounting for standard devices 0.25 kW and 0.37 kW

Mounting steps

1. Use a screwdriver to lever out the cover of the MCI slot of the standard device and remove it (1, 2).
2. Loosen the securing screw for the communication module at the standard device (3).
3. Insert the communication module into the MCI slot of the standard device (4).
4. Tighten the securing screw again (5).

kabea GmbH (Innovative Antriebe)
Kobmannstraße 47, D-66538 Neunkirchen
Telefon:+49 (0)6821/919238, Fax:+49 (0)6821/919239
<https://www.becker-antriebstechnik.org/>

5.1.2 Mounting for standard devices from 0.55 kW onwards

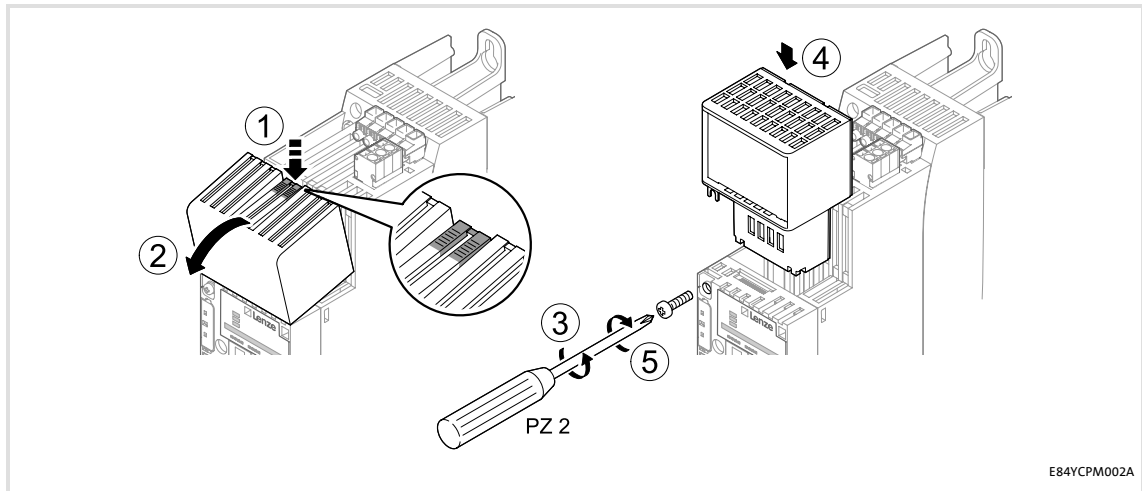

[5-2] Mounting for standard devices from 0.55 kW onwards

Mounting steps

1. Slightly impress the pressure surface on the top side of the standard device MCI slot cover (1).
2. Bend the cover forward and remove it from the standard device (2).
3. Loosen the securing screw for the communication module at the standard device (3).
4. Insert the communication module into the MCI slot of the standard device (4).
5. Tighten the securing screw again (5).

kabea GmbH (Innovative Antriebe)
Kößmannstraße 47, D-66538 Neunkirchen
Telefon:+49 (0)6821/919238, Fax:+49 (0)6821/919239
<https://www.becker-antriebstechnik.org/>

5.1.3 Replacing the communication module

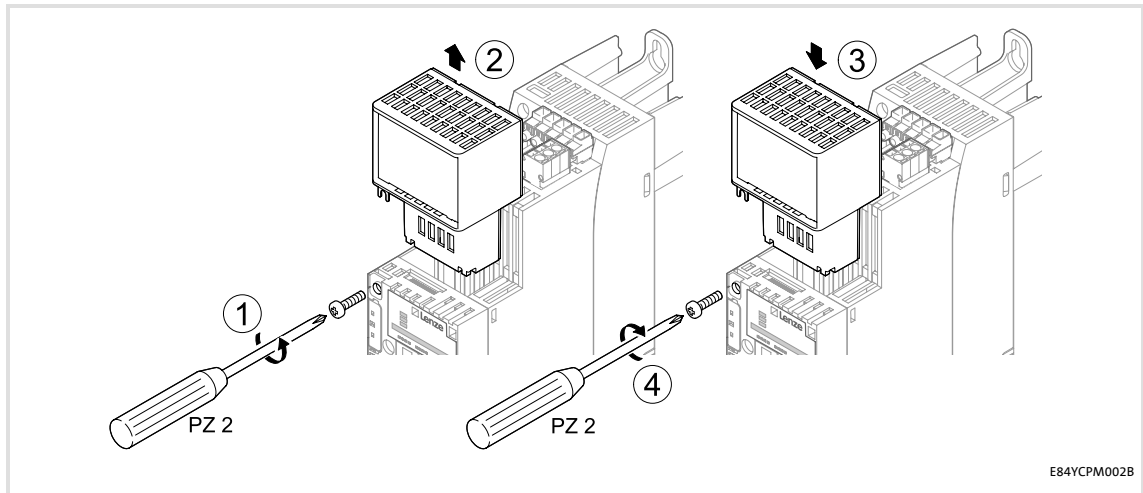

[5-3] Replacing the communication module

Mounting steps

1. Loosen the securing screw for the communication module at the standard device (1).
2. Remove the communication module from the MCI slot of the standard device (2).
3. Insert the new communication module into the MCI slot of the standard device (3).
4. Tighten the securing screw again (4).

5.2 Electrical installation



Documentation for the standard device, control system, plant/machine

Observe the notes and wiring instructions contained in this documentation.

5.2.1 EMC-compliant wiring

In typical systems, standard shielding of the Ethernet cables is sufficient.

However, in environments with a very high level of interference, EMC resistance can be improved by additionally earthing the cable shield on both sides.

For this observe the following notes:

1. Remove the plastic sheath of the cable on a length of 2 cm.
2. Fasten the cable shield onto the shield contact of the standard device.

5.2.2 Network topology

The bus system must be designed as a ring. Feed and return lines must be integrated in the same bus cable. The ring goes from the INTERBUS master via all other nodes and back again to the master.

An INTERBUS ring can consist of maximally 513 nodes (1 master + standard devices connected).

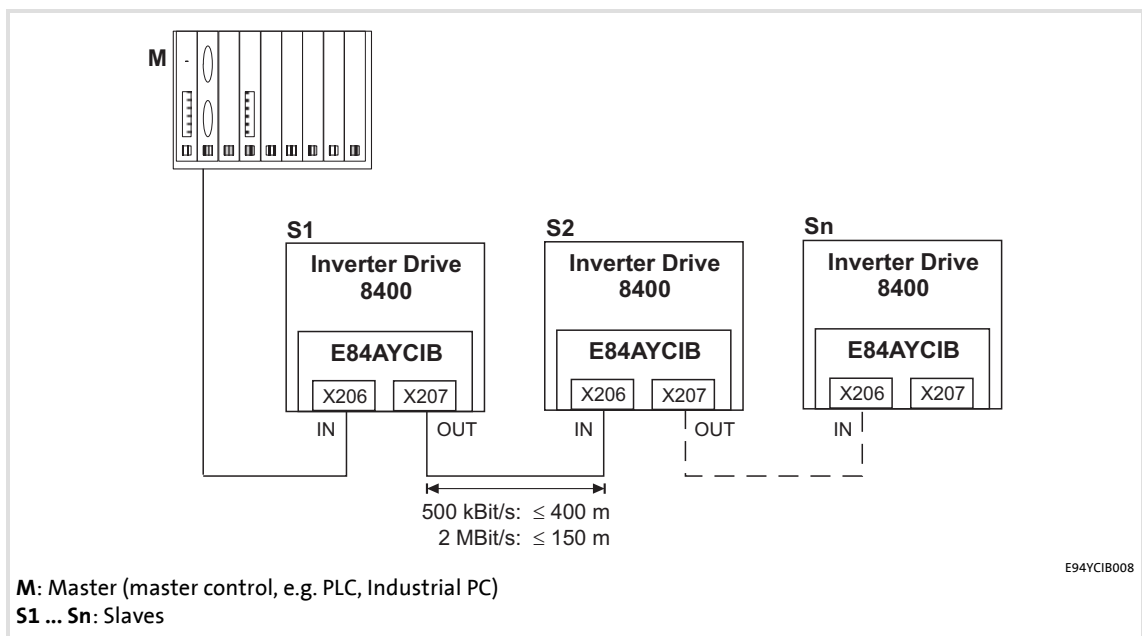

[5-4] INTERBUS ring

kabea GmbH (Innovative Antriebe)
Koßmannstraße 47, D-66538 Neunkirchen
Telefon:+49 (0)6821/919238, Fax:+49 (0)6821/919239
<https://www.becker-antriebstechnik.org/>

5.2.3 INTERBUS connection

The INTERBUS connection of the communication module is effected via **X206** (input, 9-pole Sub-D plug) and **X207** (output, 9-pole Sub-D socket).

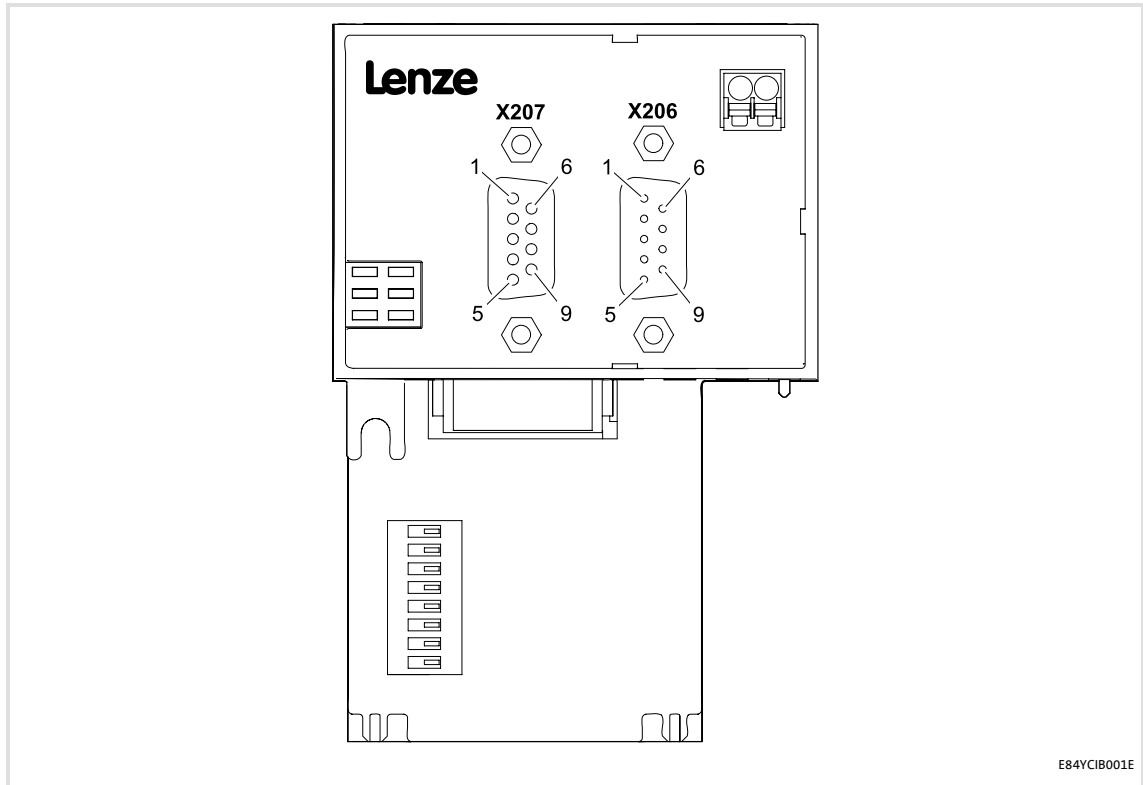

[5-5] INTERBUS terminals X206 (input) and X207 (output)

The nodes on the bus system have to be connected to each other by means of a fieldbus cable in accordance with the INTERBUS specification. INTERBUS cables are for instance produced by PHOENIX CONTACT (Germany).

▶ [Specification of the bus cable](#) (30)

Assignment of the 9-pole Sub-D plug X206 (IN)

Pin	Designation	Input/output	Description
1	DO1	Input	RS485: DO1 not inverted
2	DI1	Output	RS485: DI1 not inverted
3	GND		Reference potential
4	Free		Not assigned
5	Vcc5	Output	5 V DC
6	/DO1	Input	RS485: DO1 inverted
7	/DI1	Output	RS485: DI1 inverted
8	Vcc5	Output	5 V DC
9	Free		Not assigned

Assignment of the 9-pole Sub-D socket X207 (OUT)

Pin	Designation	Input/output	Description
1	DO2	Output	RS485: DO2 not inverted
2	DI2	Input	RS485: DI2 not inverted
3	GND		Reference potential
4	GND		
5	Vcc5	Output	5 V DC
6	/DO2	Output	RS485: DO2 inverted
7	/DI2	Input	RS485: DI2 inverted
8	Vcc5	Output	5 V DC
9	RBST	Signalling input	Connection to the outgoing INTERBUS is plugged.

kabea GmbH (Innovative Antriebe)
 Koßmannstraße 47, D-66538 Neunkirchen
 Telefon:+49 (0)6821/919238, Fax:+49 (0)6821/919239
<https://www.becker-antriebstechnik.org/>

5.2.4 Specification of the bus cable



Note!

Only use cables that meet the listed specifications.

Specification of the INTERBUS cable

Cable type	Sold by the meter (e.g. PHOENIX CONTACT: IBS RBC meter-T, order no. 28 06 28 6)
No. of conductors	3 x 2, twisted in pairs, with joint shielding
Conductor cross-section	> 0.2 mm ²
DC-cable resistance	< 96 Ω/km
Impedance (characteristic)	<ul style="list-style-type: none">• 120 Ω ± 20 % (f = 64 kHz)• 100 Ω ± 15 Ω (f > 1 MHz)
Capacitance per unit length	< 60 nF/km (f = 800 Hz)

5.2.5 Bus cable length

Adapt the baud rate according to the bus cable length:

Baud rate	Cable length between the individual INTERBUS nodes
500 kbps	Max. 400 m
2 Mbps	Max. 150 m



Note!

Select the baud rate which depends on the data volume, cycle time, and number of nodes only as high as required for the application.

5.2.6 External voltage supply

The communication module can be supplied externally with voltage via separate supply cables at the 2-pole plug connector (X205).



Note!

With external voltage supply, always use a separate power supply unit, safely separated in accordance with EN 61800-5-1 in every control cabinet ("SELV" / "PELV").

- ▶ External voltage supply of the communication module is necessary if the bus communication is to continue when the supply of the standard device fails.
- ▶ It is not possible to access the parameters of a standard device that is disconnected from the mains.

Wiring the X205 plug connector



Stop!

Only wire the plug connector if the standard device is disconnected from the mains.

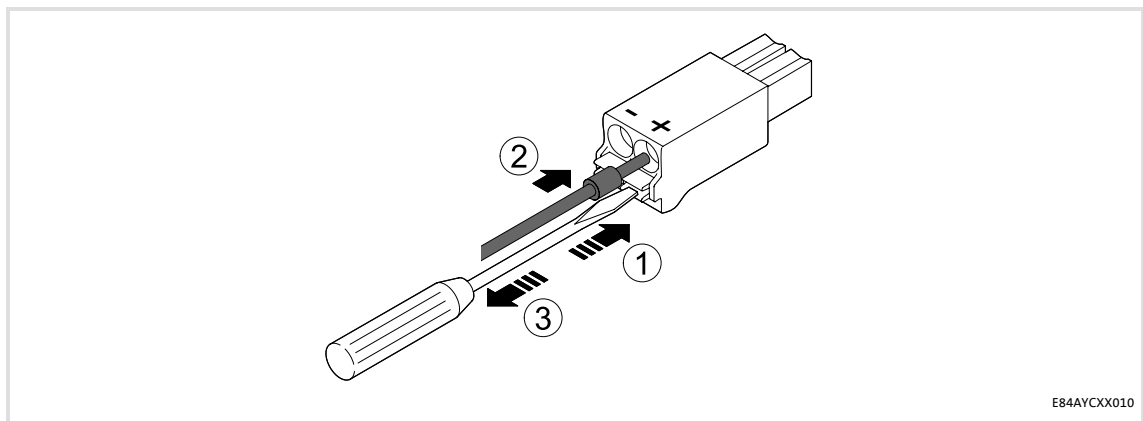

[5-6] Wiring of the 2-pole plug connector with spring connection

How to wire the plug connector with spring connection:

1. Place a screwdriver into the notch below the terminal and keep it pressed.
2. Place the supply cable in the terminal.
3. Remove the screwdriver from the notch.

kabea GmbH (Innovative Antriebe)
Kößmannstraße 47, D-66538 Neunkirchen
Telefon:+49 (0)6821/919238, Fax:+49 (0)6821/919239
<https://www.becker-antriebstechnik.org/>

Assignment of the X205 plug connector

Designation	Explanation
+	U = 24 V DC (21.6 V - 0 % ... 26.4 V + 0 %) I = 180 mA
-	Reference potential for external voltage supply

Terminal data

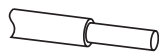
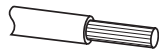
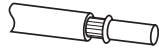
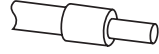
Field	Values
Electrical connection	2-pole plug connector with spring connection
Possible connections	Rigid:
	 0.2 ... 1.5 mm ² (AWG 24 ... 16)
	Flexible:
	 Without wire end ferrule 0.2 ... 1.5 mm ² (AWG 24 ... 16)
	 With wire end ferrule, without plastic sleeve 0.2 ... 1.5 mm ² (AWG 24 ... 16)
 With wire end ferrule, with plastic sleeve 0.2 ... 1.5 mm ² (AWG 24 ... 16)	
Stripping length	10 mm

kabea GmbH (Innovative Antriebe)
 Koßmannstraße 47, D-66538 Neunkirchen
 Telefon:+49 (0)6821/919238, Fax:+49 (0)6821/919239
<https://www.becker-antriebstechnik.org/>

6 Commissioning

During commissioning, system-specific data such as motor parameters, operating parameters, responses, and parameters for fieldbus communication are defined for the controller. For Lenze devices this is effected via the so-called codes.

The codes of the controller and for communication are saved non-volatilely as a data set in the memory module.

Additionally there are codes for diagnostics and monitoring of the nodes.

▶ [Parameters of the communication module](#) (📖 63)

6.1 Before initial switch-on



Stop!

Before switching on the standard device with the communication module for the first time, check the entire wiring for completeness, short circuit, and earth fault.

6.2 Possible settings through DIP switch

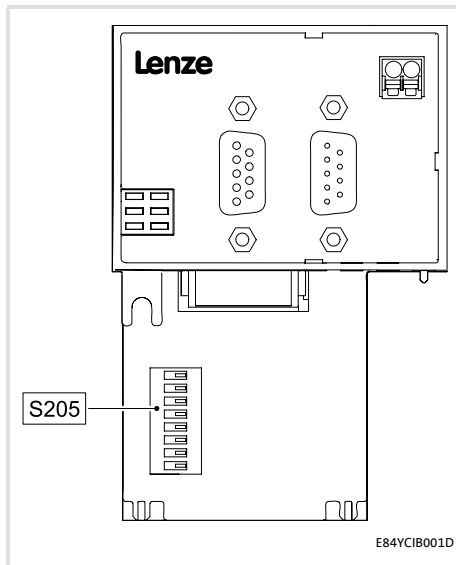

[6-1] DIP switch

The following can be set through the DIP switch (S205):

- ▶ Number of process data words (PD)
Switches: 1 ... 4 ([35](#))
- ▶ Number of parameter data words (PCP)
Switches: 5 and 6 ([36](#))
- ▶ Baud rate
Switch: 8 ([37](#))

Lenze setting: All switches "OFF"

Switch 7 has no function.



Note!

To make any modified settings take effect, switch the voltage supply of the communication module off and then on again.

▶ [Initial switch-on](#) ([39](#))

The settings can also be made via codes:

- All DIP switches = "OFF" (Lenze setting):
At switch-on, the configuration from codes [C13892](#), [C13893](#), and [C13894](#) becomes active.
- At least one DIP switch = "ON":
At switch-on, the values are accepted from the switch positions.

The data word sum (PD + PCP) may maximally amount to 10 words.

6.2.1 Setting the number of process data words (PD)

- ▶ The number of process data words (PD) can be set via switches 1 ... 4 or code [C13893](#) (for this, see [Settings in the »Engineer«](#) (38)).
- ▶ 0 ... 10 process data words can be used.
- ▶ The current setting is displayed in [C13860/2](#).



Note!

The data word sum (PD + PCP) must amount to 1 ... 10 words. Impermissible settings are reported by the LED "BE" (red blinking).

▶ [LED status displays](#) (54)

The communication module then continues to operate internally with the following values:

- PD = 2 (words)
- PCP = 1 (word)

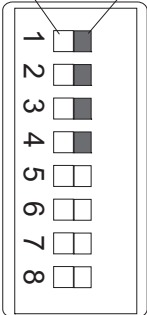
DIP switch	Number of PD	Switch				Max. number of PCP
		1	2	3	4	
OFF ON	0	OFF	OFF	OFF	OFF	4
	1	OFF	OFF	OFF	ON	
	2	OFF	OFF	ON	OFF	
	3	OFF	OFF	ON	ON	
	4	OFF	ON	OFF	OFF	
	5	OFF	ON	OFF	ON	
	6	OFF	ON	ON	OFF	
	7	OFF	ON	ON	ON	2
	8	ON	OFF	OFF	OFF	
	9	ON	OFF	OFF	ON	1
	10	ON	OFF	ON	OFF	0

kabea GmbH (Innovative Antriebe)
Kößmannstraße 47, D-66538 Neunkirchen
Telefon:+49 (0)6821/919238, Fax:+49 (0)6821/919239
<https://www.becker-antriebstechnik.org/>

6.2.2 Setting the number of parameter data words (PCP)

- ▶ The number of parameter data words (PCP) can be set via switches 5 and 6 or code [C13892](#) (for this, see [Settings in the »Engineer«](#) (p 38)).
- ▶ 0, 1, 2 or 4 parameter data words can be used.
- ▶ The current setting is displayed in [C13860/1](#).



Note!

The data word sum (PD + PCP) must amount to 1 ... 10 words. Impermissible settings are reported by the LED "BE" (red blinking).

▶ [LED status displays](#) (p 54)

The communication module then continues to operate internally with the following values:

- PD = 2 (words)
- PCP = 1 (word)

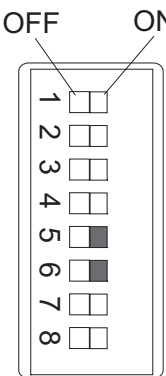
DIP switch	Number of PCP	Switch		Max. number of PD	ID code [hex]
		5	6		
	0	OFF	OFF	10	0x03
	1	OFF	ON	9	0xE3
	2	ON	OFF	8	0xE0
	4	ON	ON	6	0xE1

6.2.3 Setting the baud rate

- ▶ The baud rate can be set via switch 8 or code [C13894](#) (for this, see [Settings in the »Engineer«](#) (□ 38)).
- ▶ The current setting of the baud rate is displayed in [C13863/](#).

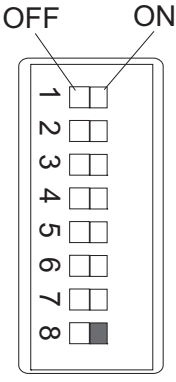
DIP switch	Switch 8	Baud rate	Max. cable length between adjacent nodes
	OFF	500 kbps	400 m
	ON	2 Mbps	150 m

6.3 Settings in the »Engineer«

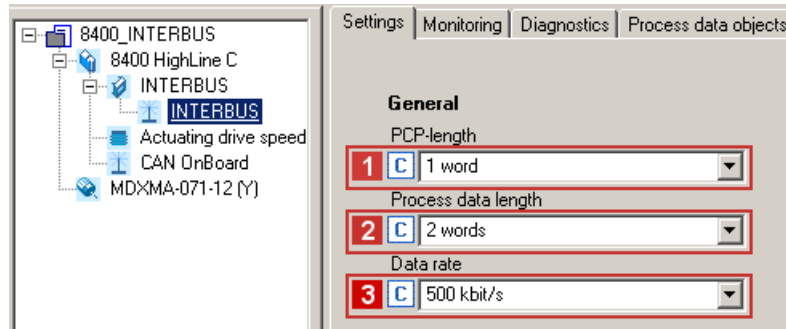

Under the **Settings** tab in the »Engineer« you can set the following parameters:

- ▶ **1** Number of parameter data words (PCP, [C13892](#))
- ▶ **2** Number of process data words (PD, [C13893](#))
- ▶ **3** Baud rate ([C13894](#))

6.4 Initial switch-on

**Documentation for the standard device**

Observe the safety instructions and information on residual hazards contained in this documentation.

**Note!****Establishing communication**

In order to establish communication via an externally supplied communication module, the standard device must be switched on as well.

After communication has been established, the power on/off state of the standard device is irrelevant.

Activating altered settings

To activate altered settings, ...

- use standard device code **C00002** to execute the device command "11: save all parameter sets", and ...
- then switch the voltage supply of the communication module off and on again.

Protection against uncontrolled restart

Following a fault (e.g. short-term mains failure), it is sometimes undesirable or even impermissible for the drive to restart.

In the Lenze setting for Inverter Drives 8400, restart protection is active.

The restart behaviour of the controller can be set using **C00142** ("autostart option"):

- **C00142 = 9** (Lenze setting)
 - The controller remains inhibited (even when the fault is no longer active).
 - Bit 0 (inhibit at power-on) and bit 3 (inhibit in the case of undervoltage) are set.
 - An explicit controller enable causes the drive to start up in a controlled manner: LOW-HIGH edge at digital input X4/RFR.
- **C00142 = 8** (enabled)
 - In order to directly enable the device at switch-on, bit 0 must be set to zero (FALSE).
 - An uncontrolled restart of the drive is possible.

kabea GmbH (Innovative Antriebe)
Kößmannstraße 47, D-66538 Neunkirchen
Telefon:+49 (0)6821/919238, Fax:+49 (0)6821/919239
<https://www.becker-antriebstechnik.org/>

7 Data transfer

The INTERBUS master and controller communicate with each other by exchanging data telegrams via INTERBUS. The user data area of the data telegram contains parameter data or process data. In the controller, the parameter data and process data are assigned to different communication channels.

Communication channels

- ▶ The process data channel transmits process data.
 - The process data are used to actuate the controller.
 - The host (master) can directly access the process data. In the PLC, for instance, the data are directly assigned to the I/O area.
 - Process data are not saved in the controller.
 - Process data are transmitted cyclically between the host and the controllers (permanent exchange of current input and output data).
 - Process data for instance are setpoints, actual values, control words, and status words.
 - In the case of Inverter Drives 8400 a maximum of 16 process data words (16 bits/word) can be exchanged for each direction.



Note!

Observe the direction of the flow of information!

- Process input data (Rx data):
 - Process data from the controller (slave) to the master
- Process output data (Tx data):
 - Process data from the master to the controller (slave)

- ▶ The parameter data channel transmits parameter data.
 - The parameter data channel provides access to all Lenze codes.
 - The transmission of parameter data usually is not time-critical.
 - Parameter data for instance are operating parameters, motor data, and diagnostics information.
 - The parameter changes must be stored via code **C00002** of the Inverter Drive 8400.
 - The parameter data channel assigns up to 4 words of the input and output data words in the master and is structured identically for both transmission directions.

kabea GmbH (Innovative Antriebe)
Kößmannstraße 47, D-66538 Neunkirchen
Telefon:+49 (0)6821/919238, Fax:+49 (0)6821/919239
<https://www.becker-antriebstechnik.org/>

8 Process data transfer

8.1 Access to process data / PDO mapping

The process data (MCI-PDOs) are transferred via the MCI interface.

- ▶ A maximum of 16 words is exchanged for each direction.
- ▶ The process data are accessed via the port blocks **LP_MciIn** and **LP_MciOut**. These port blocks are also referred to as process data channels.
- ▶ The port block **LP_MciIn** maps the MCI-PDOs received.
- ▶ The port block **LP_MciOut** maps the MCI-PDOs to be transmitted.
- ▶ The port/function block interconnection of the process data objects (PDO) is made via the Lenze »Engineer«.

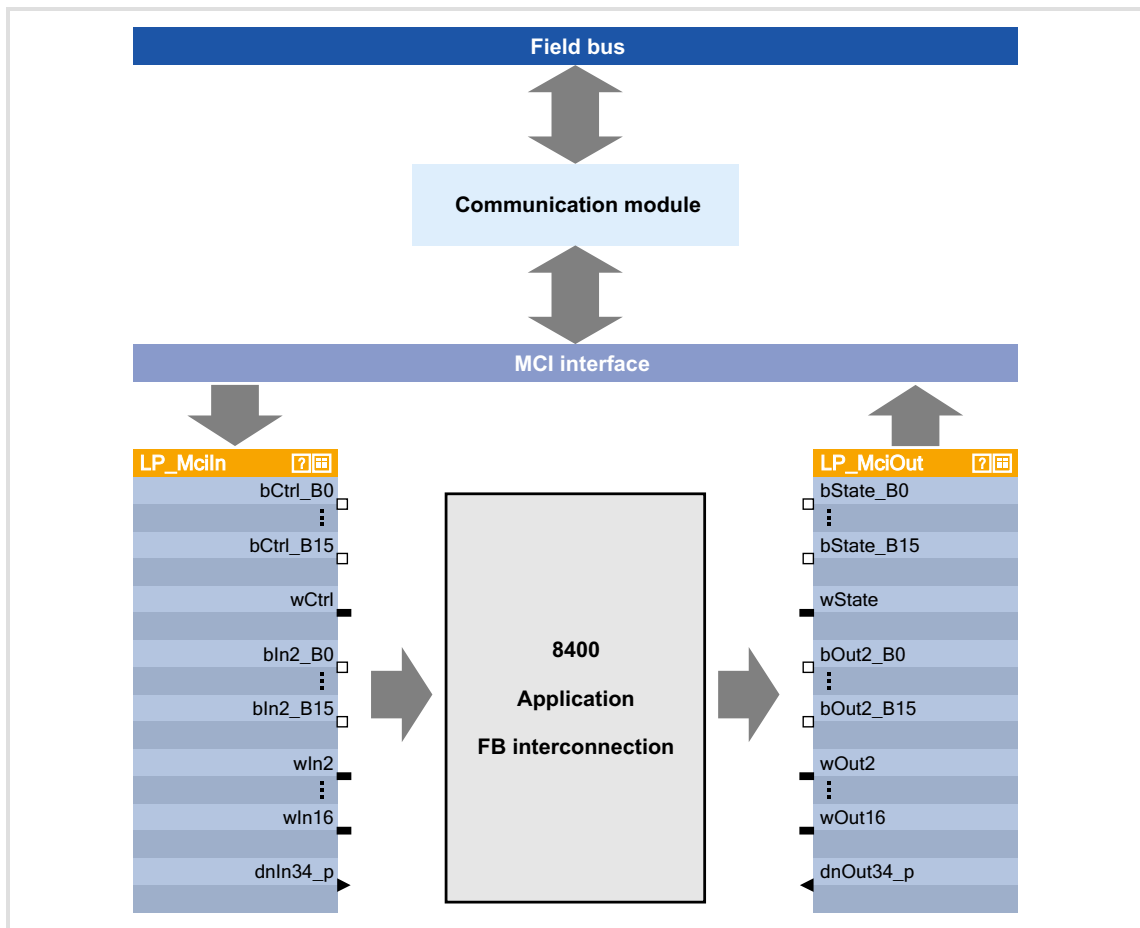

[8-1] External and internal data transfer between the bus system, controller, and application



Software manual / »Engineer« online help for the Inverter Drive 8400

Here you'll find detailed information on the port /function block interconnection in the »Engineer« and on port blocks.

kabea GmbH (Innovative Antriebe)
 Koßmannstraße 47, D-66538 Neunkirchen
 Telefon:+49 (0)6821/919238, Fax:+49 (0)6821/919239
<https://www.becker-antriebstechnik.org/>

8.3 Freely configuring the port interconnection of the process data objects (PDO)



How to freely configure the port interconnection in the »Engineer«:

1. Go to the **Process data objects** tab to click the **Go to application** button.

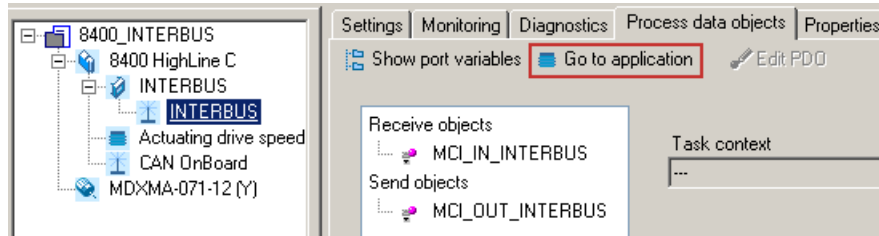

2. Select the "MCI_IN" or "MCI_OUT" port blocks in the **Ports** tab via mouse-click and activate them with the **Activate** button.

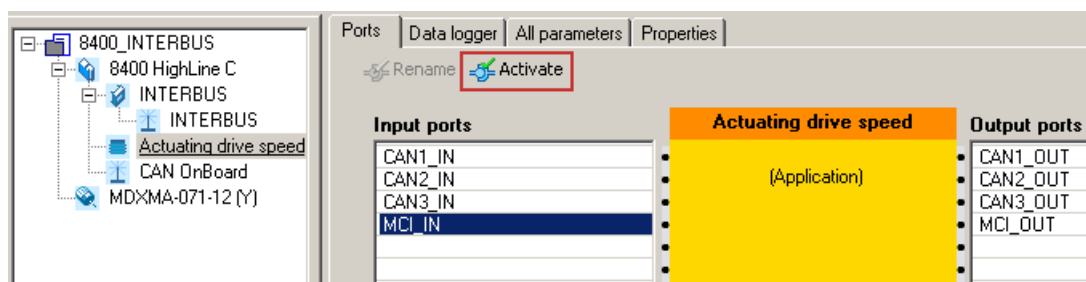

kabea GmbH (Innovative Antriebe)
 Koßmannstraße 47, D-66538 Neunkirchen
 Telefon:+49 (0)6821/919238, Fax:+49 (0)6821/919239
<https://www.becker-antriebstechnik.org/>

E84AYCIB communication manual (INTERBUS)

Process data transfer

Freely configuring the port interconnection of the process data objects (PDO)

3. Click the **Change variable...** button.

The screenshot shows the configuration software interface with the following sections:

- Ports:** Includes tabs for 'Data logger', 'All parameters', and 'Properties'. Below are 'Rename' and 'Activate' buttons.
- Input ports:** A list containing CAN1_IN, CAN2_IN, CAN3_IN, and MCI_IN (highlighted).
- Actuating drive speed:** A yellow vertical bar with the text '(Application)' in the center.
- Output ports:** A list containing CAN1_OUT, CAN2_OUT, CAN3_OUT, and MCI_OUT.
- Mapping:** Shows 'INTERBUS/MCI_IN_INTERBUS : 0'.
- network default interconnection:** Shows '<not defined>' and a 'Network default change...' button.
- Application variables:** A table with columns: Name, Signal, Type, Length, Index, and Online. A 'Change Variable...' button is highlighted with a red box to the right of the table.

Name	Signal	Type	Length	Index	Online
WORD_1	[not connected]	WORD	16	C876/1	offline
WORD_2	[not connected]	WORD	16	C876/2	offline
WORD_3	[not connected]	WORD	16	C876/3	offline
WORD_4	[not connected]	WORD	16	C876/4	offline
WORD_5	[not connected]	WORD	16	C876/5	offline
WORD_6	[not connected]	WORD	16	C876/6	offline
WORD_7	[not connected]	WORD	16	C876/7	offline
WORD_8	[not connected]	WORD	16	C876/8	offline
WORD_9	[not connected]	WORD	16	C876/9	offline

kabea GmbH (Innovative Antriebe)
Kossmannstraße 47, D-66538 Neunkirchen
Telefon:+49 (0)6821/919238, Fax:+49 (0)6821/919239
<https://www.becker-antriebstechnik.org/>

4. The  button serves to assign signals to the process data words in the *Assignment signal --> function block* dialog box.
→ Select signals and then click the **OK** button.

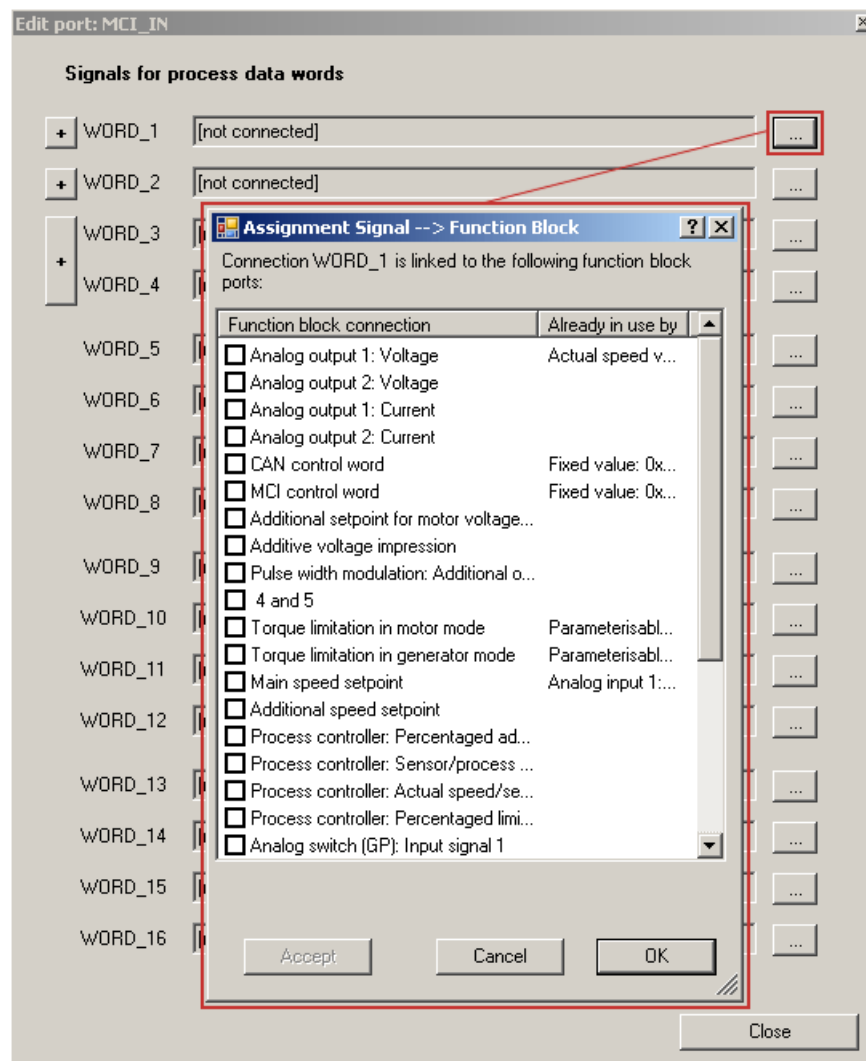



kabea GmbH (Innovative Antriebe)
Koßmannstraße 47, D-66538 Neunkirchen
Telefon:+49 (0)6821/919238, Fax:+49 (0)6821/919239
<https://www.becker-antriebstechnik.org/>

E84AYCIB communication manual (INTERBUS)

Process data transfer

Freely configuring the port interconnection of the process data objects (PDO)

Moreover you can assign signals to the individual control and status bits at the WORD_1... WORD_4 process data words via the  and  buttons.
→ Select the signals and then click OK.

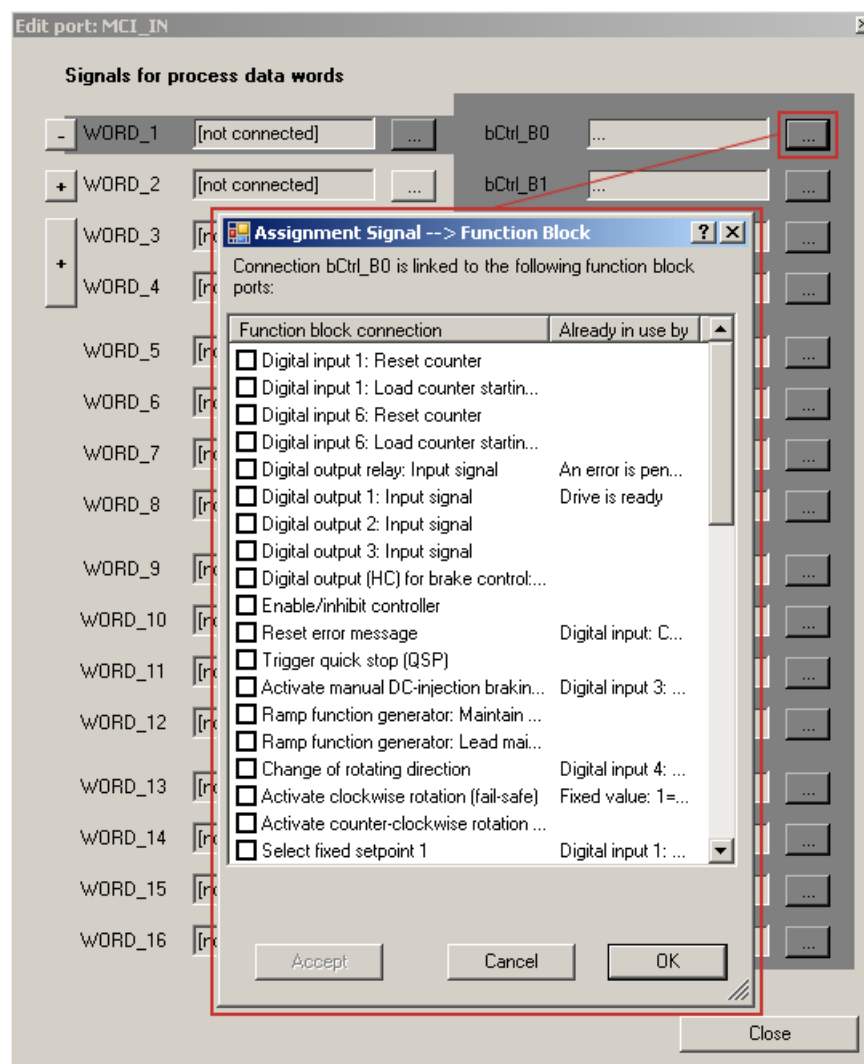

kabea GmbH (Innovative Antriebe)
Koßmannstraße 47, D-66538 Neunkirchen
Telefon:+49 (0)6821/919238, Fax:+49 (0)6821/919239
<https://www.becker-antriebstechnik.org/>



Tip!

When the port blocks "LP_MciIn" and "LP_MciOut" are activated (see 1.), they will be visible in the »FB Editor«. Here you can also assign signals to the process data words.

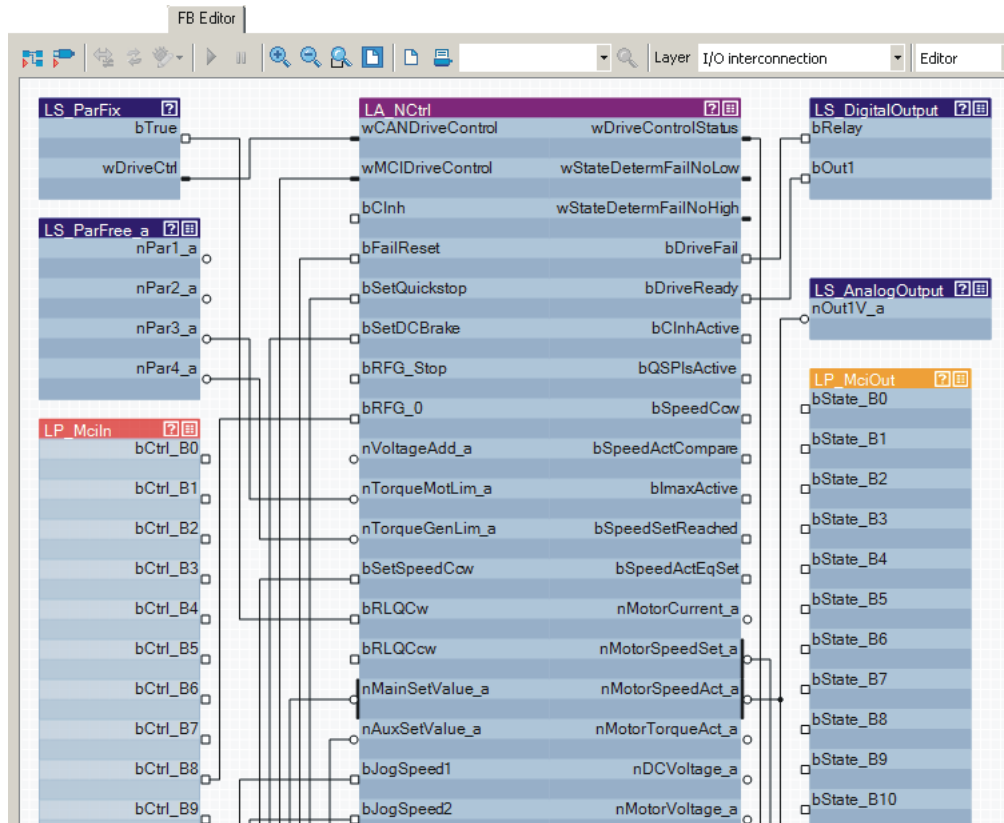

kabea GmbH (Innovative Antriebe)
 Koßmannstraße 47, D-66538 Neunkirchen
 Telefon:+49 (0)6821/919238, Fax:+49 (0)6821/919239
<https://www.becker-antriebstechnik.org/>

9 Parameter data transfer

9.1 Addressing of the parameter data

The parameter data are addressed via codes which are listed in the form of a code table in this communication manual and in the corresponding documentation for your controller.

▶ [Parameter reference](#) (63)

Addressing of the Lenze parameters

With the INTERBUS parameter data channel, the parameters of a device are not directly addressed via the Lenze codes but via an index and subindex.

The conversion is made via an offset (24575 or 0x5FFF):

- ▶ INTERBUS index (dec) = 24575 - Lenze code number (dec)
- ▶ INTERBUS index (hex) = 0x5FFF - Lenze code number (hex)

Example of C00105 (deceleration time quick stop (QSP))

- ▶ INTERBUS index (dec) = 24575 - 105 = 24470
- ▶ INTERBUS index (hex) = 0x5FFF - 0x69 = 0x5F96

9.2 Initialising PCP communication

Make entries into the CRL (communication relation list) so that communication between the INTERBUS master and the communication module can take place.

Make the following entries in the CRL of the INTERBUS master:

Field name	Entry
Communication reference	2
Connection type	Master slave acyclic
Connection attribute	Defined
Max-PDU Sending-High-Prio	0
Max-PDU Sending-Low-Prio	64
Max-PDU Receiving-High-Prio	0
Max-PDU Receiving-Low-Prio	64
Supported Services Request	0x803000
Supported Services Response	0x000000
Maximum SCC	1
Maximum RCC	1
Maximum SAC	1
Maximum RAC	1

kabea GmbH (Innovative Antriebe)
Kößmannstraße 47, D-66538 Neunkirchen
Telefon:+49 (0)6821/919238, Fax:+49 (0)6821/919239
<https://www.becker-antriebstechnik.org/>

9.3 Supported PMS services

Parameters are transferred via the PCP channel (PCP = Peripherals Communication Protocol). This is executed via PMS services.

In the following, only parameters and their contents are given that are returned by the Lenze controllers. All other transfer parameters of the given PMS services can be obtained from the corresponding descriptions of the INTERBUS master.

The following PMS services are supported by Lenze controllers:

- ▶ Initiate: Establish a connection from the INTERBUS master to the controller
- ▶ Abort: Abort connection
- ▶ Reject: Reject impermissible PMS service
- ▶ Read: Read parameters
- ▶ Write: Write parameters
- ▶ Get-OD: Read out the object directory
- ▶ Identify: Identification of the controller
- ▶ Status: Read the status of the controller

9.3.1 Initiate

The "Initiate" PMS service establishes a logic connection between the INTERBUS master and the communication module.

The controller provides the following parameters:

Designation	Value	Description
Profile number	0	No profile is supported.
Password	0	The password function of INTERBUS is not supported.
Access groups	0	There are no access groups.
Access-Protection Supported	TRUE	Access protection is supported.
Version OD	0	Version of the object directory

9.3.2 Abort

The "Abort" PMS service aborts a logic connection between the INTERBUS master and the communication module.

9.3.3 Reject

The "Reject" PMS service rejects a non-supported PMS service.

kabea GmbH (Innovative Antriebe)
 Koßmannstraße 47, D-66538 Neunkirchen
 Telefon:+49 (0)6821/919238, Fax:+49 (0)6821/919239
<https://www.becker-antriebstechnik.org/>

9.3.4 Read / Write

The "Read" PMS service reads parameters from the controller. The controller outputs the requested parameter or an error message.

The "Write" PMS service writes to parameters of the controller. The controller outputs a positive feedback or an error message.

The following error messages can occur:

Error Class	Error Code	Additional Code [hex]	Description
6	3	0x00	No access authorisation
6	5	0x10	Impermissible job parameter
6	5	0x11	Invalid subindex
6	5	0x12	Data length too big
6	5	0x13	Data length too small
6	6	0x00	Object is not a parameter
6	7	0x00	Object does not exist
6	8	0x00	Data types do not comply with each other
8	0	0x00	Job cannot be executed
8	0	0x20	Job currently cannot be executed
8	0	0x21	Cannot be executed because of local control
8	0	0x22	Cannot be executed because of device state
8	0	0x30	Quit value range / parameter can only be changed when the controller is inhibited.
8	0	0x31	Value of the parameter is too high
8	0	0x32	Value of the parameter is too low
8	0	0x33	Subparameter outside the value range
8	0	0x34	Value of the subparameter is too high
8	0	0x35	Value of the subparameter is too low
8	0	0x36	Maximum value is lower than minimum value
8	0	0x41	Communication object cannot be displayed on process data
8	0	0x42	Length of the process data exceeded
8	0	0x43	General collision with other values

9.3.5 Get-OD

The "Get-OD" PMS service reads out the object description for every parameter and data type.

9.3.6 Identify

The "Identify" PMS service provides information on how to identify the controller.

The controller with the plugged-on communication module provides the following parameters for this:

Parameter	Type	Description
Device manufacturer	Visible string	Company name "Lenze"
Device type	Visible-string (15 characters)	Device name for the controller and the communication module
Device version	Visible-string (15 characters)	Firmware version of the controller and the communication module

Example: Visible string "device type" (15 characters)

1	2	3	4	5	6	7	8	9	10	11	12	13	14	15
E	8	4		A	F	G	H	C		A	F	Y	I	B

Character	Description
1 ... 3	Product range of the controller and the communication module (E84 = 8400 series)
4	Blank
5 ... 6	A: Version of the controller F: Firmware of the controller
7 ... 9	G: Device / controller SC: StateLine C HC: HighLine C
10	Blank
11 ... 12	A: Version of the communication module F: Firmware of the communication module
13 ... 15	Y: Communication module IB: INTERBUS

Structure of the visible string "device version" (15 characters)

1	2	3	4	5	6	7	8	9	10	11	12	13	14	15
0	4	.	0	0		0	1	.	0	0				

Character	Description
1 ... 5	Firmware version of the controller (from C00099/0, e.g. "04.00.xx.yy", without internal revision status ["xx"] and build status ["yy"])
6	Blank
7 ... 11	Firmware version of the communication module (from C13902 , e.g. "01.00.xx.yy", without internal revision status ["xx"] and build status ["yy"])
12 ... 15	Blank

kabea GmbH (Innovative Antriebe)
 Koßmannstraße 47, D-66538 Neunkirchen
 Telefon:+49 (0)6821/919238, Fax:+49 (0)6821/919239
<https://www.becker-antriebstechnik.org/>

9.3.7 Status

The "Status" PMS service provides status information about the controller.

The controller provides the following values:

Status	Value	Description
Logical status	0 = ready for communication	Information about the current operating mode of the controller with regard to communication
Physical status	<ul style="list-style-type: none">• 0 = ready for operation (device state "OPERATION ENABLED")• 1 = ready for operation to a limited extent (all other device states)	Information about the current operating status of the controller.
Local Detail	0	Is not supported.

10 Monitoring

Communication fault

- ▶ If INTERBUS communication is interrupted, e.g. due to cable break or INTERBUS master failure, no process data are transmitted to the slave in the "IBS-ACTIVE" (57) status.
- ▶ After the time to be parameterised by the user in [C13881](#) has elapsed, the response parameterised in [C13880/1](#) is executed in the controller.

Settings in the »Engineer«

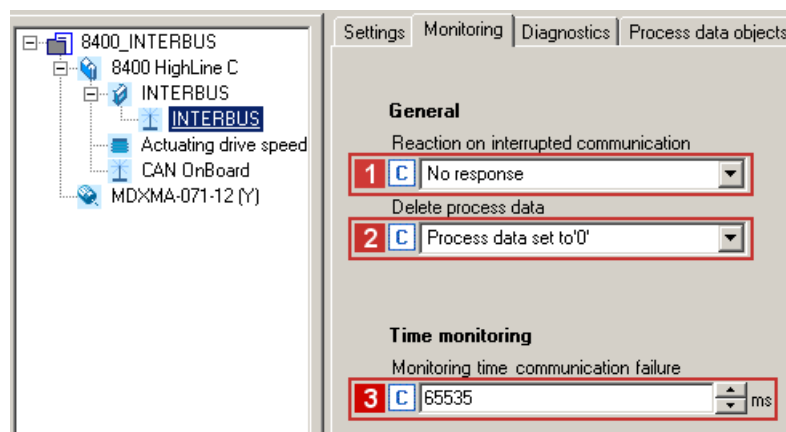

Under the **Settings** tab in the »Engineer« you can set the following parameters:

- ▶ **1** Reaction on interrupted INTERBUS communication ([C13880/1](#))
- ▶ **2** Delete process data ([C13885](#))
 - Setting of the process data which the controller is to process further for maintaining internal communication when the INTERBUS has failed.
- ▶ **3** Monitoring time for INTERBUS communication failure ([C13881](#))

kabea GmbH (Innovative Antriebe)
 Koßmannstraße 47, D-66538 Neunkirchen
 Telefon:+49 (0)6821/919238, Fax:+49 (0)6821/919239
<https://www.becker-antriebstechnik.org/>

11 Diagnostics

For fault diagnostics, the INTERBUS module is provided with the LEDs on the front. Furthermore code [C13861](#) can be used to query the current bus status (for this, see [Diagnostics with the »Engineer«](#) (57)).

11.1 LED status displays



Note!

In normal operation only the LEDs **MS** (55) and **BS** (56) should be lit constantly.





The following status displays are distinguished:

- ▶ [Module status displays](#) (55)
- ▶ [Fieldbus status displays](#) (56)

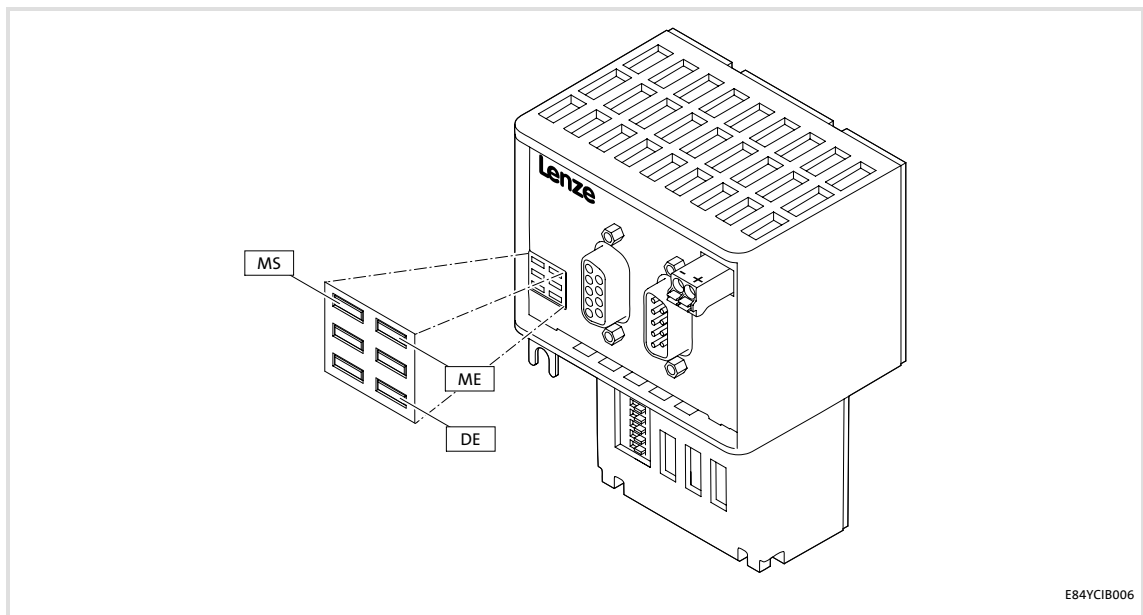
11.1.1 Module status displays

The LEDs **MS**, **ME** and **DE** display the module status.





LED	Colour	Status	Description
MS	Green	On	 <p>The communication module is supplied with voltage and has established a connection to the standard device.</p>
		Blinking	 <p>The communication module is supplied with voltage, but has not established a connection to the standard device. (Standard device is switched off, initialising or not present.)</p>
ME	Red	Blinking	 <p>An error in the communication module has occurred.</p>
DE	Red	On	 <p>The communication module is not accepted by the standard device (see notes in the documentation for the standard device), or the standard device is not active.</p>

11.1.2 Fieldbus status displays

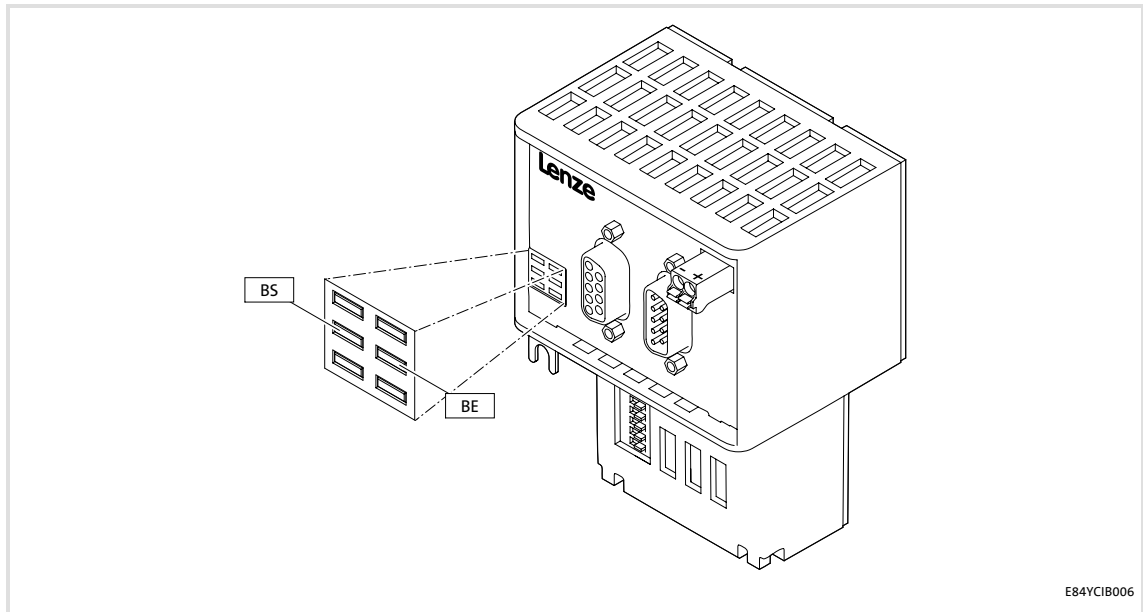
The LEDs **BS** and **BE** display the fieldbus status.



E84YCIB006

LED	Colour	Status	Description
BS	Green	Off	The communication module is not active on the fieldbus. Data cycles are not executed.
		Blinking	 <p>Communication has been established via the communication module. The INTERBUS is active. Data cycles are executed.</p>
BE	Red	On	 <p>INTERBUS communication is interrupted. Data cycles are not executed.</p>
		Blinking	 <p>Impermissible setting:</p> <ul style="list-style-type: none"> • Data word sum (PD + PCP) > 10 • Data word sum (PD + PCP) = 0 <p>The communication module has been initialised and continues to operate internally with the following values:</p> <ul style="list-style-type: none"> • PD = 2 (words) • PCP = 1 (word)

11.2 Querying the current bus status

Code [C13861](#) displays the current bus status of the INTERBUS node:

Value of C13861 [hex]	Bus status	Description
0xyyy0	IBS-INIT	Initialisation
0xyyy1	IBS-ACTIVE	The bus is active. Data cycles are executed.
0xyyy2	IBS-READY	The bus is ready for operation. No data cycles are executed.

yyy = device-internal use

Diagnostics with the »Engineer«

In the »Engineer« the **Diagnostics** tab serves to display various pieces of diagnostic INTERBUS information.

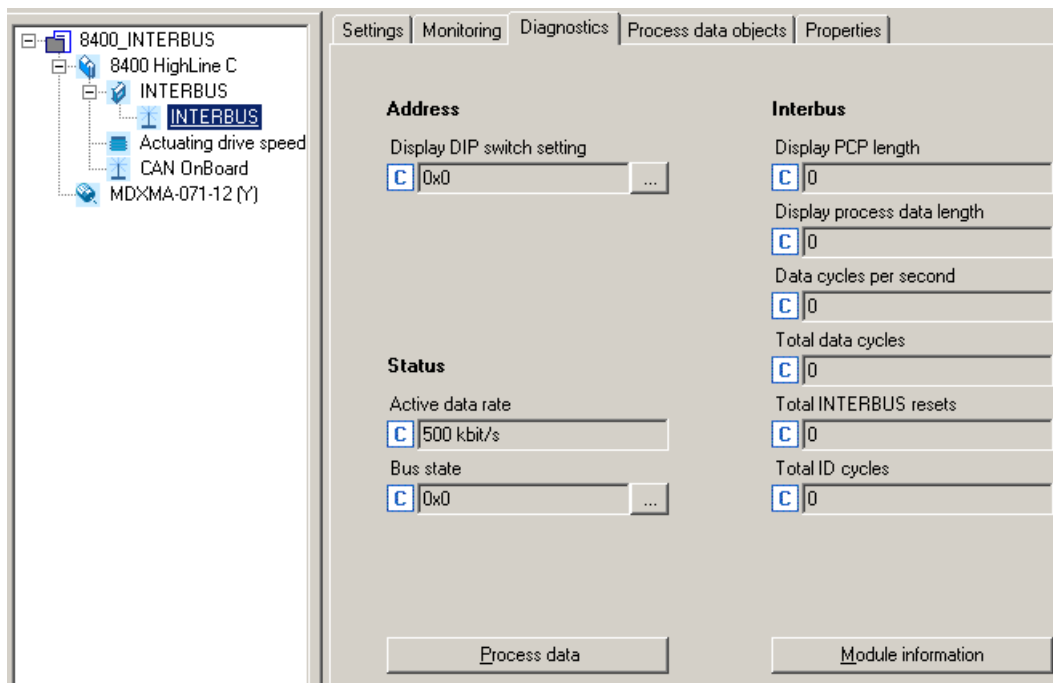

kabea GmbH (Innovative Antriebe)
 Koßmannstraße 47, D-66538 Neunkirchen
 Telefon:+49 (0)6821/919238, Fax:+49 (0)6821/919239
<https://www.becker-antriebstechnik.org/>

11.3 Diagnostic data

- ▶ Pending diagnostic data are signalled by the master via an alarm message to the slave.
- ▶ Errors and warnings in the standard device and the plugged-in module are transmitted to the master as extended diagnostic messages.
- ▶ The diagnostic data can be viewed via the hexadecimal representation of the Engineering tool.

Bytes	Meaning	Value [hex]
1 ... 6	Diagnostics block header	0x0010 001C 0100
7 ... 8	Alarm type	0x0001 (Diagnosis)
9 ... 12	API	0x0000 0000
13, 14	Slot number	0x0001 / 0x0002
15, 16	Subslot number	0x0001
17 ... 20	Module ID number	ID according to module
21 ... 24	Submodule number	ID according to module
25, 26	Alarm specifier	0xB000
27, 28	User structure identifier	0x0001
29 ... 32	Error code of the Inverter Drive 8400	

Error code of the Inverter Drive 8400

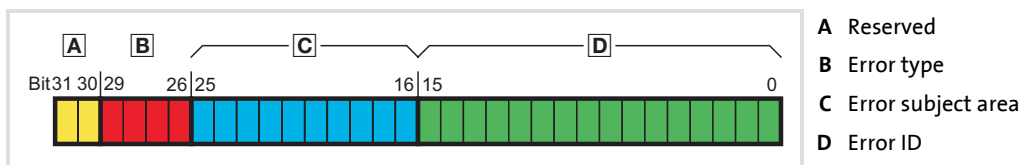

[11-1] Structure of the error number

- ▶ Bytes 29 ... 32 of the diagnostic message contain the error code of the Inverter Drive 8400.
- ▶ The logbook and standard device code **C00165** show the error number in the following syntax to improve the legibility:
[error type].[error subject area no.].[error ID]



Software manual/»Engineer« online help for the Inverter Drive 8400

Here you'll find detailed information on the structure and the contents of the error codes.

kabea GmbH (Innovative Antriebe)
 Koßmannstraße 47, D-66538 Neunkirchen
 Telefon:+49 (0)6821/919238, Fax:+49 (0)6821/919239
<https://www.becker-antriebstechnik.org/>

12 Error messages

This chapter provides the error messages of the communication module as a supplement to the error list in the software manual and the »Engineer« online help for the Inverter Drive 8400.



Software manual/»Engineer« online help for the Inverter Drive 8400

Here you'll find general information on diagnostics & fault analysis and error messages.

12.1 Short overview (A-Z) of the INTERBUS error messages

The following table contains all error messages of the communication module in alphabetical order with the preset error response and, if available, the parameter for setting the error response.



Tip!

When you click the cross-reference in the last column, you will get to the detailed description (causes and remedies) of the corresponding error message.

Error text	Error type	Subject area no.	Error no.	Adjustable in	Detailed information
Communication stack reset	Error	444	33062	-	0x01bc8126
Data exchange stopped	No response	444	33073	C13880/1	0x01bc8131
Internal error	Error	444	24592	-	0x01bc6010
Internal error	Error	444	24593	-	0x01bc6011
Internal error	Error	444	24832	-	0x01bc6100
Internal error	Error	444	24833	-	0x01bc6101
Invalid configuration	Warning	444	33061	-	0x01bc8125
Invalid initialisation	Warning	444	33063	-	0x01bc8127
Invalid module configuration	Error	444	25648	-	0x01bc6430
Invalid parameter set	Error	444	25631	-	0x01bc641f
Lenze setting loaded	Error	444	25632	-	0x01bc6420
Lost connection to 8400 base device	Error	444	12544	-	0x01bc3100
Memory not accessible	Error	444	21809	-	0x01bc5531
Memory read error	Error	444	21810	-	0x01bc5532
Memory write error	Error	444	21811	-	0x01bc5533

kabea GmbH (Innovative Antriebe)
 Koßmannstraße 47, D-66538 Neunkirchen
 Telefon:+49 (0)6821/919238, Fax:+49 (0)6821/919239
<https://www.becker-antriebstechnik.org/>

12.2 Possible causes and remedies

This chapter includes a list of all error messages of the communication module in numerically ascending order of the error number. Possible causes and remedies as well as responses to error messages are described in detail.



Tip!

A list of all error messages of the communication module in alphabetical order is provided in the previous chapter "[Short overview \(A-Z\) of the INTERBUS error messages](#)" (p. 59).

Lost connection to 8400 base device [0x01bc3100]

Response (Lenze setting in bold)		Setting: not possible
<input type="checkbox"/> None <input type="checkbox"/> System fault <input checked="" type="checkbox"/> Fault <input type="checkbox"/> Trouble <input type="checkbox"/> Quick stop by trouble <input type="checkbox"/> Warning locked <input type="checkbox"/> Warning <input type="checkbox"/> Information		
Cause	Remedy	
Network cable (plug) is defective. Network cable at INTERBUS terminal X206 (IN) or X207 (OUT) is disconnected.	Check network cable (plug) and replace it, if required. Plug in network cable at INTERBUS terminal X206 (IN) or X207 (OUT).	

Memory not accessible [0x01bc5531]

Response (Lenze setting in bold)		Setting: not possible
<input type="checkbox"/> None <input type="checkbox"/> System fault <input checked="" type="checkbox"/> Fault <input type="checkbox"/> Trouble <input type="checkbox"/> Quick stop by trouble <input type="checkbox"/> Warning locked <input type="checkbox"/> Warning <input type="checkbox"/> Information		
Cause	Remedy	
Memory could not be accessed.	Send module with error description to Lenze.	

Memory read error [0x01bc5532]

Response (Lenze setting in bold)		Setting: not possible
<input type="checkbox"/> None <input type="checkbox"/> System fault <input checked="" type="checkbox"/> Fault <input type="checkbox"/> Trouble <input type="checkbox"/> Quick stop by trouble <input type="checkbox"/> Warning locked <input type="checkbox"/> Warning <input type="checkbox"/> Information		
Cause	Remedy	
Parameter in the memory module could not be read.	Repeat download of the application (including module).	

Memory write error [0x01bc5533]

Response (Lenze setting in bold)		Setting: not possible
<input type="checkbox"/> None <input type="checkbox"/> System fault <input checked="" type="checkbox"/> Fault <input type="checkbox"/> Trouble <input type="checkbox"/> Quick stop by trouble <input type="checkbox"/> Warning locked <input type="checkbox"/> Warning <input type="checkbox"/> Information		
Cause	Remedy	
Parameter in the memory module could not be written.	Repeat download of the application (including module).	

Internal error [0x01bc6010]

Response (Lenze setting in bold)		Setting: not possible	
<input type="checkbox"/> None <input type="checkbox"/> System fault <input checked="" type="checkbox"/> Fault <input type="checkbox"/> Trouble <input type="checkbox"/> Quick stop by trouble <input type="checkbox"/> Warning locked <input type="checkbox"/> Warning <input type="checkbox"/> Information			
Cause		Remedy	
Communication module is defective.		Send communication module with error description to Lenze.	

Internal error [0x01bc6011]

Response (Lenze setting in bold)		Setting: not possible	
<input type="checkbox"/> None <input type="checkbox"/> System fault <input checked="" type="checkbox"/> Fault <input type="checkbox"/> Trouble <input type="checkbox"/> Quick stop by trouble <input type="checkbox"/> Warning locked <input type="checkbox"/> Warning <input type="checkbox"/> Information			
Cause		Remedy	
Communication module is defective.		Send communication module with error description to Lenze.	

Internal error [0x01bc6100]

Response (Lenze setting in bold)		Setting: not possible	
<input type="checkbox"/> None <input type="checkbox"/> System fault <input checked="" type="checkbox"/> Fault <input type="checkbox"/> Trouble <input type="checkbox"/> Quick stop by trouble <input type="checkbox"/> Warning locked <input type="checkbox"/> Warning <input type="checkbox"/> Information			
Cause		Remedy	
Communication module is defective.		Send communication module with error description to Lenze.	

Internal error [0x01bc6101]

Response (Lenze setting in bold)		Setting: not possible	
<input type="checkbox"/> None <input type="checkbox"/> System fault <input checked="" type="checkbox"/> Fault <input type="checkbox"/> Trouble <input type="checkbox"/> Quick stop by trouble <input type="checkbox"/> Warning locked <input type="checkbox"/> Warning <input type="checkbox"/> Information			
Cause		Remedy	
Communication module is defective.		Send communication module with error description to Lenze.	

Invalid parameter set [0x01bc641f]

Response (Lenze setting in bold)		Setting: not possible	
<input type="checkbox"/> None <input type="checkbox"/> System fault <input checked="" type="checkbox"/> Fault <input type="checkbox"/> Trouble <input type="checkbox"/> Quick stop by trouble <input type="checkbox"/> Warning locked <input type="checkbox"/> Warning <input type="checkbox"/> Information			
Cause		Remedy	
Loading of an active parameter set was not possible.		Repeat download of the application (including module).	

Lenze setting loaded [0x01bc6420]

Response (Lenze setting in bold)		Setting: not possible	
<input type="checkbox"/> None <input type="checkbox"/> System fault <input checked="" type="checkbox"/> Fault <input type="checkbox"/> Trouble <input type="checkbox"/> Quick stop by trouble <input type="checkbox"/> Warning locked <input type="checkbox"/> Warning <input type="checkbox"/> Information			
Cause		Remedy	
Access via standard device to the parameter set in the memory module failed.		Repeat download of the application (including module).	

E84AYCIB communication manual (INTERBUS)

Error messages

Possible causes and remedies

Invalid module configuration [0x01bc6430]

Response (Lenze setting in bold)		Setting: not possible
<input type="checkbox"/> None <input type="checkbox"/> System fault <input checked="" type="checkbox"/> Fault <input type="checkbox"/> Trouble <input type="checkbox"/> Quick stop by trouble <input type="checkbox"/> Warning locked <input type="checkbox"/> Warning <input type="checkbox"/> Information		
Cause	Remedy	
Module configuration is faulty.	Check and correct module configuration.	

Invalid configuration [0x01bc8125]

Response (Lenze setting in bold)		Setting: not possible
<input type="checkbox"/> None <input type="checkbox"/> System fault <input type="checkbox"/> Fault <input type="checkbox"/> Trouble <input type="checkbox"/> Quick stop by trouble <input type="checkbox"/> Warning locked <input checked="" type="checkbox"/> Warning <input type="checkbox"/> Information		
Cause	Remedy	
The active configuration is invalid: <ul style="list-style-type: none">• Data word sum (PD + PCP) > 10 words• Data word sum (PD + PCP) = 0	Adapt the number of PD and PCP: <ul style="list-style-type: none">• Data word sum (PD + PCP) = 1 ... 10 words	

Communication stack reset [0x01bc8126]

Response (Lenze setting in bold)		Setting: not possible
<input type="checkbox"/> None <input type="checkbox"/> System fault <input checked="" type="checkbox"/> Fault <input type="checkbox"/> Trouble <input type="checkbox"/> Quick stop by trouble <input type="checkbox"/> Warning locked <input type="checkbox"/> Warning <input type="checkbox"/> Information		
Cause	Remedy	
Error during processing the INTERBUS services	Execute reinitialisation by the master.	

Invalid initialisation [0x01bc8127]

Response (Lenze setting in bold)		Setting: not possible
<input type="checkbox"/> None <input type="checkbox"/> System fault <input type="checkbox"/> Fault <input type="checkbox"/> Trouble <input type="checkbox"/> Quick stop by trouble <input type="checkbox"/> Warning locked <input checked="" type="checkbox"/> Warning <input type="checkbox"/> Information		
Cause	Remedy	
The INTERBUS initialisation has failed.	Execute reinitialisation by the master.	

Data exchange stopped [0x01bc8131]

Response (Lenze setting in bold)		Setting: C13880/1
<input checked="" type="checkbox"/> None <input type="checkbox"/> System fault <input checked="" type="checkbox"/> Fault <input type="checkbox"/> Trouble <input checked="" type="checkbox"/> Quick stop by trouble <input checked="" type="checkbox"/> Warning locked <input type="checkbox"/> Warning <input checked="" type="checkbox"/> Information		
Cause	Remedy	
The data exchange at the INTERBUS has been terminated.	<ul style="list-style-type: none">• Check cables and connections.• Execute reinitialisation by the master.	

13 Parameter reference

This chapter supplements the parameter list and the table of attributes in the software manual and the »Engineer« online help for the Inverter Drive 8400 by parameters of the E84AYCIB communication module (INTERBUS).



Software manual/»Engineer« online help for the Inverter Drive 8400

Here you'll find general information about parameters.

13.1 Parameters of the communication module

This chapter lists the parameters of the E84AYCIB communication module (INTERBUS) in numerically ascending order.

C13850

Parameter Name:	Data type: UNSIGNED_16 Index: 10725 _d = 29E5 _h
C13850 All words to master	
Display of the process data words which are transmitted from the communication module to the master.	
<ul style="list-style-type: none"> Subcodes 1 ... 16 display all process data words to the master. Only those which are configured are valid. Maximally the first 10 words are relevant to the E84AYCIB INTERBUS module. 	
Display area (min. value unit max. value)	
0	65535
Subcodes	Information
C13850/1	
...	
C13850/16	
<input checked="" type="checkbox"/> Read access <input type="checkbox"/> Write access <input type="checkbox"/> CINH <input type="checkbox"/> PLC-STOP <input type="checkbox"/> No transfer <input type="checkbox"/> PDO_MAP_RX <input type="checkbox"/> PDO_MAP_TX <input type="checkbox"/> COM <input type="checkbox"/> MOT	

C13851

Parameter Name:	Data type: UNSIGNED_16 Index: 10724 _d = 29E4 _h
C13851 All words from master	
Display of the process data words which are transmitted from the master to the communication module.	
<ul style="list-style-type: none"> Subcodes 1 ... 16 display all process data words from the master. Only those which are configured are valid. Maximally the first 10 words are relevant to the E84AYCIB INTERBUS module. 	
Display area (min. value unit max. value)	
0	65535
Subcodes	Information
C13851/1	
...	
C13851/16	
<input checked="" type="checkbox"/> Read access <input type="checkbox"/> Write access <input type="checkbox"/> CINH <input type="checkbox"/> PLC-STOP <input type="checkbox"/> No transfer <input type="checkbox"/> PDO_MAP_RX <input type="checkbox"/> PDO_MAP_TX <input type="checkbox"/> COM <input type="checkbox"/> MOT	

kabea GmbH (Innovative Antriebe)
 Koßmannstraße 47, D-66538 Neunkirchen
 Telefon:+49 (0)6821/919238, Fax:+49 (0)6821/919239
<https://www.becker-antriebstechnik.org/>

E84AYCIB communication manual (INTERBUS)

Parameter reference

Parameters of the communication module

C13852

Parameter | Name: **C13852 | All words to standard device** Data type: UNSIGNED_16
Index: 10723_d = 29E3_h

Display of the process data words which are transmitted from the communication module to the standard device.

- Subcodes 1 ... 16 display all process data words to the standard device. Maximally the first 10 words are relevant to the E84AYCIB INTERBUS module.

Display area (min. value unit max. value)	
0 65535	
Subcodes	Information
C13852/1	
...	
C13852/16	

Read access Write access CINH PLC-STOP No transfer PDO_MAP_RX PDO_MAP_TX COM MOT

C13853

Parameter | Name: **C13853 | All words from standard device** Data type: UNSIGNED_16
Index: 10722_d = 29E2_h

Display of the process data words which are transmitted from the standard device to the communication module.

- Subcodes 1 ... 16 display all process data words from the standard device. Maximally the first 10 words are relevant to the E84AYCIB INTERBUS module.

Display area (min. value unit max. value)	
0 65535	
Subcodes	Information
C13853/1	
...	
C13853/16	

Read access Write access CINH PLC-STOP No transfer PDO_MAP_RX PDO_MAP_TX COM MOT

C13860

Parameter | Name: **C13860 | Active settings** Data type: UNSIGNED_8
Index: 10715_d = 29DB_h

Display of the set number for

- Parameter data words (PCP)
- Process data words (PD) to be used (16 bits/word)

Display area (min. value unit max. value)	
0 255	
Subcodes	Information
C13860/1	Display of PCP data length
C13860/2	Display of process data length

Read access Write access CINH PLC-STOP No transfer PDO_MAP_RX PDO_MAP_TX COM MOT

kabea GmbH (Innovative Antriebe)
Kößmannstraße 47, D-66538 Neunkirchen
Telefon:+49 (0)6821/919238, Fax:+49 (0)6821/919239
<https://www.becker-antriebstechnik.org/>

C13861

Parameter Name: C13861 Bus status	Data type: BITFIELD_16 Index: 10714 _d = 29DA _h
Display of the current bus status ▶ Querying the current bus status (□ 57)	
Meaning of the resulting hexadecimal values:	
<ul style="list-style-type: none"> • 0xyyy0 = IBS-INIT • 0xyyy1 = IBS-ACTIVE • 0xyyy2 = IBS-READY 	
Value is bit coded:	Information
Bit 0 Bit 0	
... ..	
Bit 15 Bit 15	
<input checked="" type="checkbox"/> Read access <input type="checkbox"/> Write access <input type="checkbox"/> CINH <input type="checkbox"/> PLC-STOP <input type="checkbox"/> No transfer <input type="checkbox"/> PDO_MAP_RX <input type="checkbox"/> PDO_MAP_TX <input type="checkbox"/> COM <input type="checkbox"/> MOT	

C13862

Parameter Name: C13862 Counter	Data type: UNSIGNED_16 Index: 10713 _d = 29D9 _h
Counter for cycles and INTERBUS resets	
Display area (min. value unit max. value)	
0 65535	
Subcodes	Information
C13862/1	Data cycles per second
C13862/2	Total data cycles
C13862/3	Number of INTERBUS resets
C13862/4	Number of ID cycles
<input checked="" type="checkbox"/> Read access <input type="checkbox"/> Write access <input type="checkbox"/> CINH <input type="checkbox"/> PLC-STOP <input type="checkbox"/> No transfer <input type="checkbox"/> PDO_MAP_RX <input type="checkbox"/> PDO_MAP_TX <input type="checkbox"/> COM <input type="checkbox"/> MOT	

C13863

Parameter Name: C13863 Active baud rate	Data type: UNSIGNED_8 Index: 10712 _d = 29D8 _h
Display of the set baud rate	
Selection list (read only)	
0 500 kbps	
1 2.00 Mbps	
<input checked="" type="checkbox"/> Read access <input type="checkbox"/> Write access <input type="checkbox"/> CINH <input type="checkbox"/> PLC-STOP <input type="checkbox"/> No transfer <input type="checkbox"/> PDO_MAP_RX <input type="checkbox"/> PDO_MAP_TX <input type="checkbox"/> COM <input type="checkbox"/> MOT	

kabea GmbH (Innovative Antriebe)
 Koßmannstraße 47, D-66538 Neunkirchen
 Telefon:+49 (0)6821/919238, Fax:+49 (0)6821/919239
<https://www.becker-antriebstechnik.org/>

E84AYCIB communication manual (INTERBUS)

Parameter reference

Parameters of the communication module

C13880

Parameter Name:		Data type: UNSIGNED_8
C13880 Reaction on communication failure		Index: 10695 _d = 29C7 _h
Monitoring response in case of a communication fault A change in the monitoring response becomes effective immediately. ▶ Communication fault (53)		
Selection list		
0	No response	
1	Error	
3	Quick stop by trouble	
4	Warning locked	
6	Information	
Subcodes	Lenze setting	Information
C13880/1	0: No response	Response to interrupted INTERBUS communication
<input checked="" type="checkbox"/> Read access <input checked="" type="checkbox"/> Write access <input type="checkbox"/> CINH <input type="checkbox"/> PLC-STOP <input type="checkbox"/> No transfer <input type="checkbox"/> PDO_MAP_RX <input type="checkbox"/> PDO_MAP_TX <input type="checkbox"/> COM <input type="checkbox"/> MOT		

C13881

Parameter Name:		Data type: UNSIGNED_16	
C13881 Monitoring time for Interbus communication failure		Index: 10694 _d = 29C6 _h	
If the "IBS-ACTIVE" status (INTERBUS is active and data are cyclically exchanged) is quit, the response parameterised in C13880/1 is executed after the monitoring time set for the data exchange has elapsed. <ul style="list-style-type: none">• The value "65535" in this code deactivates monitoring.• A change in monitoring is effective immediately. ▶ Communication fault (53)			
Setting range (min. value unit max. value)		Lenze setting	
0	ms	65535	65535 ms
<input checked="" type="checkbox"/> Read access <input checked="" type="checkbox"/> Write access <input type="checkbox"/> CINH <input type="checkbox"/> PLC-STOP <input type="checkbox"/> No transfer <input type="checkbox"/> PDO_MAP_RX <input type="checkbox"/> PDO_MAP_TX <input type="checkbox"/> COM <input type="checkbox"/> MOT			

C13885

Parameter Name:		Data type: UNSIGNED_8
C13885 Delete process data		Index: 10690 _d = 29C2 _h
Setting of the process data which the controller is to process further for maintaining internal communication when the INTERBUS has failed.		
Selection list (Lenze setting printed in bold)		
0	Use of the last master process data	
1	Process data are set to the value '0'	
<input checked="" type="checkbox"/> Read access <input checked="" type="checkbox"/> Write access <input type="checkbox"/> CINH <input type="checkbox"/> PLC-STOP <input type="checkbox"/> No transfer <input type="checkbox"/> PDO_MAP_RX <input type="checkbox"/> PDO_MAP_TX <input type="checkbox"/> COM <input type="checkbox"/> MOT		

kabea GmbH (Innovative Antriebe)
Koßmannstraße 47, D-66538 Neunkirchen
Telefon:+49 (0)6821/919238, Fax:+49 (0)6821/919239
<https://www.becker-antriebstechnik.org/>

C13892

Parameter | Name: **C13892 | PCP - length** Data type: UNSIGNED_8
Index: 10683_d = 29BB_h

Setting of the number of the parameter data words to be used (PCP)

The setting is activated ...

- if all DIP switches (S205) are in the "OFF" position;
- after executing the "11: Save start parameters" device command via standard device code C00002 and performing another mains switching of the communication module/drive afterwards.

▶ [Setting the number of parameter data words \(PCP\)](#) (□ 36)

Selection list (Lenze setting printed in bold)	
0	No PCB data
1	1 word
2	2 words
4	4 words

Read access Write access CINH PLC-STOP No transfer PDO_MAP_RX PDO_MAP_TX COM MOT

C13893

Parameter | Name: **C13893 | Process data length** Data type: UNSIGNED_8
Index: 10682_d = 29BA_h

Setting of the number of the process data words to be used (PD)

The setting is activated ...

- if all DIP switches (S205) are in the "OFF" position;
- after executing the "11: Save start parameters" device command via standard device code C00002 and performing another mains switching of the communication module/drive afterwards.

▶ [Setting the number of process data words \(PD\)](#) (□ 35)

Selection list (Lenze setting printed in bold)	
0	No process data
1	1 word
2	2 words
3	3 words
4	4 words
5	5 words
6	6 words
7	7 words
8	8 words
9	9 words
10	10 words

Read access Write access CINH PLC-STOP No transfer PDO_MAP_RX PDO_MAP_TX COM MOT

kabea GmbH (Innovative Antriebe)
 Koßmannstraße 47, D-66538 Neunkirchen
 Telefon:+49 (0)6821/919238, Fax:+49 (0)6821/919239
<https://www.becker-antriebstechnik.org/>

E84AYCIB communication manual (INTERBUS)

Parameter reference

Parameters of the communication module

C13894

Parameter | Name: **C13894 | Baud rate** Data type: UNSIGNED_8
Index: 10681_d = 29B9_h

Setting of the baud rate

The setting is activated ...

- if all DIP switches (S205) are in the "OFF" position;
- after executing the "11: Save start parameters" device command via standard device code C0002 and performing another mains switching of the communication module/drive afterwards.

▶ [Setting the baud rate](#) (📖 37)

Selection list (Lenze setting printed in bold)

0	500 kbps
1	2.00 Mbps

Read access Write access CINH PLC-STOP No transfer PDO_MAP_RX PDO_MAP_TX COM MOT

C13900

Parameter | Name: **C13900 | Firmware product type** Data type: VISIBLE_STRING
Index: 10675_d = 29B3_h

Display of the product type (string with a length of 8 bytes)

The following identification code is output: "E94AFYIB".

Read access Write access CINH PLC-STOP No transfer PDO_MAP_RX PDO_MAP_TX COM MOT

C13901

Parameter | Name: **C13901 | Firmware compilation date** Data type: VISIBLE_STRING
Index: 10674_d = 29B2_h

Display of the compilation date of the firmware (string with a length of 20 bytes)

The date ("MMM TT JJJ") and time ("hh:mm:ss") are output, e.g. "Mar 21 2005 12:31:21".

Read access Write access CINH PLC-STOP No transfer PDO_MAP_RX PDO_MAP_TX COM MOT

C13902

Parameter | Name: **C13902 | Firmware version** Data type: VISIBLE_STRING
Index: 10673_d = 29B1_h

Display of the firmware version (string with a length of 11 bytes)

The identification code is output, e.g. "01.00.00.00".

Read access Write access CINH PLC-STOP No transfer PDO_MAP_RX PDO_MAP_TX COM MOT

kabea GmbH (Innovative Antriebe)
Koßmannstraße 47, D-66538 Neunkirchen
Telefon:+49 (0)6821/919238, Fax:+49 (0)6821/919239
<https://www.becker-antriebstechnik.org/>

C13920

Parameter | Name:

C13920 | Display DIP switch setting

Data type: BITFIELD_8

Index: 10655_d = 299F_h

Display of the current DIP switch position

- The set PCP data length is displayed in [C13860/1](#).
- The set process data length is displayed in [C13860/2](#).
- The set baud rate is displayed in [C13863](#).

▶ [Possible settings through DIP switch](#) (□ 34)

Value is bit coded:	Information
Bit 0 DIP 8	Baud rate
Bit 1 DIP 7	No function
Bit 2 DIP 6	Number of parameter data words (PCP)
Bit 3 DIP 5	
Bit 4 DIP 4	Number of process data words (PD)
Bit 5 DIP 3	
Bit 6 DIP 2	
Bit 7 DIP 1	

Read access
 Write access
 CINH
 PLC-STOP
 No transfer
 PDO_MAP_RX
 PDO_MAP_TX
 COM
 MOT

kabea GmbH (Innovative Antriebe)
 Koßmannstraße 47, D-66538 Neunkirchen
 Telefon:+49 (0)6821/919238, Fax:+49 (0)6821/919239
<https://www.becker-antriebstechnik.org/>

13.2 Table of attributes

The table of attributes contains information required for communicating with the controller via parameters.

How to read the table of attributes:

Column	Meaning	Entry		
Code	Parameter name	Cxxxxx		
Name	Parameter short text (display text)	<i>Text</i>		
Index	dec	Index by which the parameter is addressed. The subindex for array variables corresponds to the Lenze subcode number.	24575 - Lenze code number	Is only required for access via a bus system.
	hex		5FFF _h - Lenze code number	
Data	DS	Data structure	E	Single variable (one parameter element only)
			A	Array variable (multiple parameter elements)
	DA	Number of array elements (subcodes)	<i>Number</i>	
Data type	DT	Data type	BITFIELD_8	1 byte, bit-coded
			BITFIELD_16	2 bytes, bit-coded
			BITFIELD_32	4 bytes, bit-coded
			INTEGER_8	1 byte with sign
			INTEGER_16	2 bytes, with sign
			INTEGER_32	4 bytes with sign
			UNSIGNED_8	1 byte without sign
			UNSIGNED_16	2 bytes, without sign
			UNSIGNED_32	4 bytes, without sign
			VISIBLE_STRING	ASCII string
			OCTET_STRING	
	Factor	Factor for data transmission via a bus system, depending on the number of decimal positions	<i>Factor</i>	1 = no decimal positions 10 = 1 decimal position 100 = 2 decimal positions 1000 = 3 decimal positions
Access	R	Read access	<input checked="" type="checkbox"/> Reading permitted	
	W	Write access	<input checked="" type="checkbox"/> Writing permitted	
	CINH	Controller inhibit required	<input checked="" type="checkbox"/> Writing is only possible when the controller is inhibited	

kabea GmbH (Innovative Antriebe)
 Koßmannstraße 47, D-66538 Neunkirchen
 Telefon:+49 (0)6821/919238, Fax:+49 (0)6821/919239
<https://www.becker-antriebstechnik.org/>

Table of attributes

Code	Name	Index		Data				Access		
		dec	hex	DS	DA	DT	Factor	R	W	CINH
C13850	All words to master	10725	29E5	A	16	UNSIGNED_16	1	<input checked="" type="checkbox"/>		
C13851	All words from master	10724	29E4	A	16	UNSIGNED_16	1	<input checked="" type="checkbox"/>		
C13852	All words to standard device	10723	29E3	A	16	UNSIGNED_16	1	<input checked="" type="checkbox"/>		
C13853	All words from standard device	10722	29E2	A	16	UNSIGNED_16	1	<input checked="" type="checkbox"/>		
C13860	Active settings	10715	29DB	A	2	UNSIGNED_8	1	<input checked="" type="checkbox"/>		
C13861	Bus status	10714	29DA	E	1	BITFIELD_16		<input checked="" type="checkbox"/>		
C13862	Counter	10713	29D9	A	4	UNSIGNED_16	1	<input checked="" type="checkbox"/>		
C13863	Active baud rate	10712	29D8	E	1	UNSIGNED_8	1	<input checked="" type="checkbox"/>		
C13880	Reaction on communication failure	10695	29C7	A	1	UNSIGNED_8	1	<input checked="" type="checkbox"/>	<input checked="" type="checkbox"/>	
C13881	Monitoring time for Interbus communication failure	10694	29C6	E	1	UNSIGNED_16	1	<input checked="" type="checkbox"/>	<input checked="" type="checkbox"/>	
C13885	Delete process data	10690	29C2	E	1	UNSIGNED_8	1	<input checked="" type="checkbox"/>	<input checked="" type="checkbox"/>	
C13892	PCP - length	10683	29BB	E	1	UNSIGNED_8	1	<input checked="" type="checkbox"/>	<input checked="" type="checkbox"/>	
C13893	Process data length	10682	29BA	E	1	UNSIGNED_8	1	<input checked="" type="checkbox"/>	<input checked="" type="checkbox"/>	
C13894	Baud rate	10681	29B9	E	1	UNSIGNED_8	1	<input checked="" type="checkbox"/>	<input checked="" type="checkbox"/>	
C13900	Firmware product type	10675	29B3	E	1	VISIBLE_STRING		<input checked="" type="checkbox"/>		
C13901	Firmware compilation date	10674	29B2	E	1	VISIBLE_STRING		<input checked="" type="checkbox"/>		
C13902	Firmware version	10673	29B1	E	1	VISIBLE_STRING		<input checked="" type="checkbox"/>		
C13920	Display DIP switch setting	10655	299F	E	1	BITFIELD_8		<input checked="" type="checkbox"/>		

kabea GmbH (Innovative Antriebe)
 Koßmannstraße 47, D-66538 Neunkirchen
 Telefon:+49 (0)6821/919238, Fax:+49 (0)6821/919239
<https://www.becker-antriebstechnik.org/>

14 Index

Zahlen

- 9-pole Sub-D plug [29](#)
- 9-pole Sub-D socket [29](#)

A

- Abort (PMS service) [49](#)
- Access to process data [41](#)
- Activating altered settings [39](#)
- Active baud rate (C13863) [65](#)
- Active settings (C13860) [64](#)
- Addressing of the Lenze parameters [48](#)
- Addressing of the parameter data [48](#)
- All words from master (C13851) [63](#)
- All words from standard device (C13853) [64](#)
- All words to master (C13850) [63](#)
- All words to standard device (C13852) [64](#)
- Application as directed [14](#)
- Application notes (representation) [11](#)
- Approvals [17](#)
- Assignment of the 9-pole Sub-D plug [29](#)
- Assignment of the 9-pole Sub-D socket [29](#)

B

- Baud rate [17](#)
- Baud rate (C13894) [68](#)
- Before initial switch-on [33](#)
- Bus cable length [30](#)
- Bus status (C13861) [65](#)

C

- C13850 | All words to master [63](#)
- C13851 | All words from master [63](#)
- C13852 | All words to standard device [64](#)
- C13853 | All words from standard device [64](#)
- C13860 | Active settings [64](#)
- C13861 | Bus status [65](#)
- C13862 | Counter [65](#)
- C13863 | Active baud rate [65](#)
- C13880 | Reaction on communication failure [66](#)
- C13881 | Monitoring time for Interbus communication failure [66](#)
- C13885 | Delete process data [66](#)
- C13892 | PCP - length [67](#)
- C13893 | Process data length [67](#)
- C13894 | Baud rate [68](#)
- C13900 | Firmware product type [68](#)
- C13901 | Firmware compilation date [68](#)
- C13902 | Firmware version [68](#)
- C13920 | Display DIP switch setting [69](#)
- Cable length [17](#)
- Carrying out the port interconnection in the

- »Engineer« [43](#)
- Codes [63](#)
- Commissioning [33](#)
- Communication channels [40](#)
- Communication fault [53](#)
- Communication medium [17](#)
- Communication profile [17](#)
- Communication stack reset (error message) [62](#)
- Communication time [21](#)
- Conformities [17](#)
- Conventions [9](#)
- Conventions used [9](#)
- Copyright [2](#)
- Counter (C13862) [65](#)
- CRL (communication relation list) [48](#)

D

- Data exchange stopped (error message) [62](#)
- Data transfer [40](#)
- Delete process data (C13885) [66](#)
- Device- and application-specific safety instructions [13](#)
- Device protection [13](#)
- Diagnostic data [58](#)
- Diagnostic messages [58](#)
- Diagnostics [54](#)
- Diagnostics with the »Engineer« [57](#)
- Dimensions [22](#)
- DIP switch settings [34](#)
- Display DIP switch setting (C13920) [69](#)
- Document history [8](#)

E

- Electrical installation [27](#)
- EMC-compliant wiring [27](#)
- Error code of the Inverter Drive 8400 [58](#)
- Error messages [59](#)
 - Causes and remedies [60](#)
- Error messages (PCP services Read / Write) [50](#)
- Error messages (short overview) [59](#)
- Error number
 - 0x01bc3100 [60](#)
 - 0x01bc5531 [60](#)
 - 0x01bc5532 [60](#)
 - 0x01bc5533 [60](#)
 - 0x01bc6010 [61](#)
 - 0x01bc6011 [61](#)
 - 0x01bc6100 [61](#)
 - 0x01bc6101 [61](#)
 - 0x01bc641f [61](#)
 - 0x01bc6420 [61](#)
 - 0x01bc6430 [62](#)
 - 0x01bc8125 [62](#)

kabea GmbH (Innovative Antriebe)

Koßmannstraße 47, D-66538 Neunkirchen
Telefon:+49 (0)6821/919238, Fax:+49 (0)6821/919239
<https://www.becker-antriebstechnik.org/>

- 0x01bc8126 [62](#)
 - 0x01bc8127 [62](#)
 - 0x01bc8131 [62](#)
 - Establishing communication [39](#)
 - EtherCAT error messages
 - Causes and remedies [60](#)
 - External voltage supply [31](#)
- F**
- Fieldbus status displays [56](#)
 - Firmware compilation date (C13901) [68](#)
 - Firmware product type (C13900) [68](#)
 - Firmware version (C13902) [68](#)
- G**
- General data [17](#)
 - General safety instructions and application notes [12](#)
 - Get-OD (PMS service) [50](#)
- I**
- IBS-ACTIVE [57](#)
 - IBS-INIT [57](#)
 - IBS-READY [57](#)
 - Identification [14](#)
 - Identify (PMS service) [51](#)
 - Initial switch-on [39](#)
 - Initialising PCP communication [48](#)
 - Initiate (PMS service) [49](#)
 - Installation [23](#)
 - INTERBUS connection [28](#)
 - INTERBUS identification [17](#)
 - INTERBUS ring [27](#)
 - Interfaces [16](#), [17](#)
 - Internal error (error message) [61](#)
 - Invalid configuration (error message) [62](#)
 - Invalid initialisation (error message) [62](#)
 - Invalid module configuration (error message) [62](#)
 - Invalid parameter set (error message) [61](#)
- L**
- LED status displays [54](#)
 - Lenze setting loaded (error message) [61](#)
 - Lost connection to 8400 base device (error message) [60](#)
- M**
- Max. number of data words [17](#)
 - Max. PDU length [17](#)
 - Mechanical installation [24](#)
 - Memory not accessible (error message) [60](#)
 - Memory read error (error message) [60](#)
 - Memory write error (error message) [60](#)
 - Module ID [17](#)
 - Module status displays [55](#)
- Monitoring** [53](#)
- Monitoring time for Interbus communication failure (C13881) [66](#)
 - Mounting for standard devices 0.25 kW and 0.37 kW [24](#)
 - Mounting for standard devices from 0.55 kW onwards [25](#)
- N**
- Nameplate [14](#)
 - Network topology [17](#), [27](#)
 - Notes used [11](#)
 - Number of nodes [17](#)
- O**
- Operating conditions [17](#)
- P**
- Parameter data transfer [48](#)
 - Parameter data words (PCP) [17](#)
 - Parameter reference [63](#)
 - Parameters of the communication module [63](#)
 - PCP - length (C13892) [67](#)
 - PDO mapping [41](#)
 - PMS services [49](#)
 - Process data length (C13893) [67](#)
 - Process data transfer [41](#)
 - Process data words (PD) [17](#)
 - Processing time [21](#)
 - Product description [14](#)
 - Product features [15](#)
 - PROFINET error messages (short overview) [59](#)
 - Protection against uncontrolled restart [39](#)
 - Protection of persons [13](#)
 - Protective insulation [18](#)
 - Protocol data [21](#)
- Q**
- Querying the bus status [57](#)
 - Querying the current bus status [57](#)
- R**
- Reaction on communication failure (C13880) [66](#)
 - Read (PMS service) [50](#)
 - Reject (PMS service) [49](#)
 - Replacing the communication module [26](#)
 - Residual hazards [13](#)
- S**
- Safety instructions [12](#)
 - Safety instructions (representation) [11](#)
 - Setting the baud rate [37](#)
 - Setting the number of parameter data words (PCP) [36](#)
 - Setting the number of process data words (PD) [35](#)

Beckhoff Automation GmbH (Innovative Antriebe)
 Koßmannstraße 47, D-66538 Neunkirchen
 Telefon:+49 (0)6821/919238, Fax:+49 (0)6821/919239
<https://www.becker-antriebstechnik.org/>

Settings in the »Engineer« [38](#)
Specification of the bus cable [30](#)
Status (PMS service) [52](#)
Status displays (LEDs) [54](#)
Supported PMS services [49](#)
System error messages [59](#)

T

Table of attributes [70](#)
Target group [7](#)
Technical data [17](#)
Terminals [16](#), [32](#)
Terminology used [10](#)
Terms [10](#)
Type of node [17](#)

U

Using the communication module [14](#)

V

Validity of the documentation [7](#)
Voltage supply [17](#), [31](#)

W

Write (PCP service) [50](#)



© 11/2010



Lenze Drives GmbH
Postfach 10 13 52
D-31763 Hameln
Germany



+49 (0)51 54 / 82-0



+49 (0)51 54 / 82-28 00



Lenze@Lenze.de



www.Lenze.com

Service Lenze Service GmbH
Breslauer Straße 3
32699 Extertal
Germany



00 80 00 24 4 68 77 (24 h helpline)



+49 (0)51 54 / 82-11 12



Service@Lenze.de

EDS84AYCIB ■ 13362260 ■ EN 4.0 ■ TD17

kabea GmbH (Innovative Antriebe)^{7 6 5 4 3 2 1}

Koßmannstraße 47, D-66538 Neunkirchen

Telefon:+49 (0)6821/919238, Fax:+49 (0)6821/919239

<https://www.becker-antriebstechnik.org/>